



NASA Ames Arc Jet Complex High Enthalpy Testing



SILICON
VALLEY

AMES RESEARCH CENTER

Ernest Fretter

Thermophysics Facilities Branch

Entry Systems and Technology Division

What we are about

- Arc Jet Complex provides the tools to study thermal protection materials and to test their responses to a high enthalpy scenario that matches hypersonic entry into an atmosphere of a planet or moon.



The Division's Approach

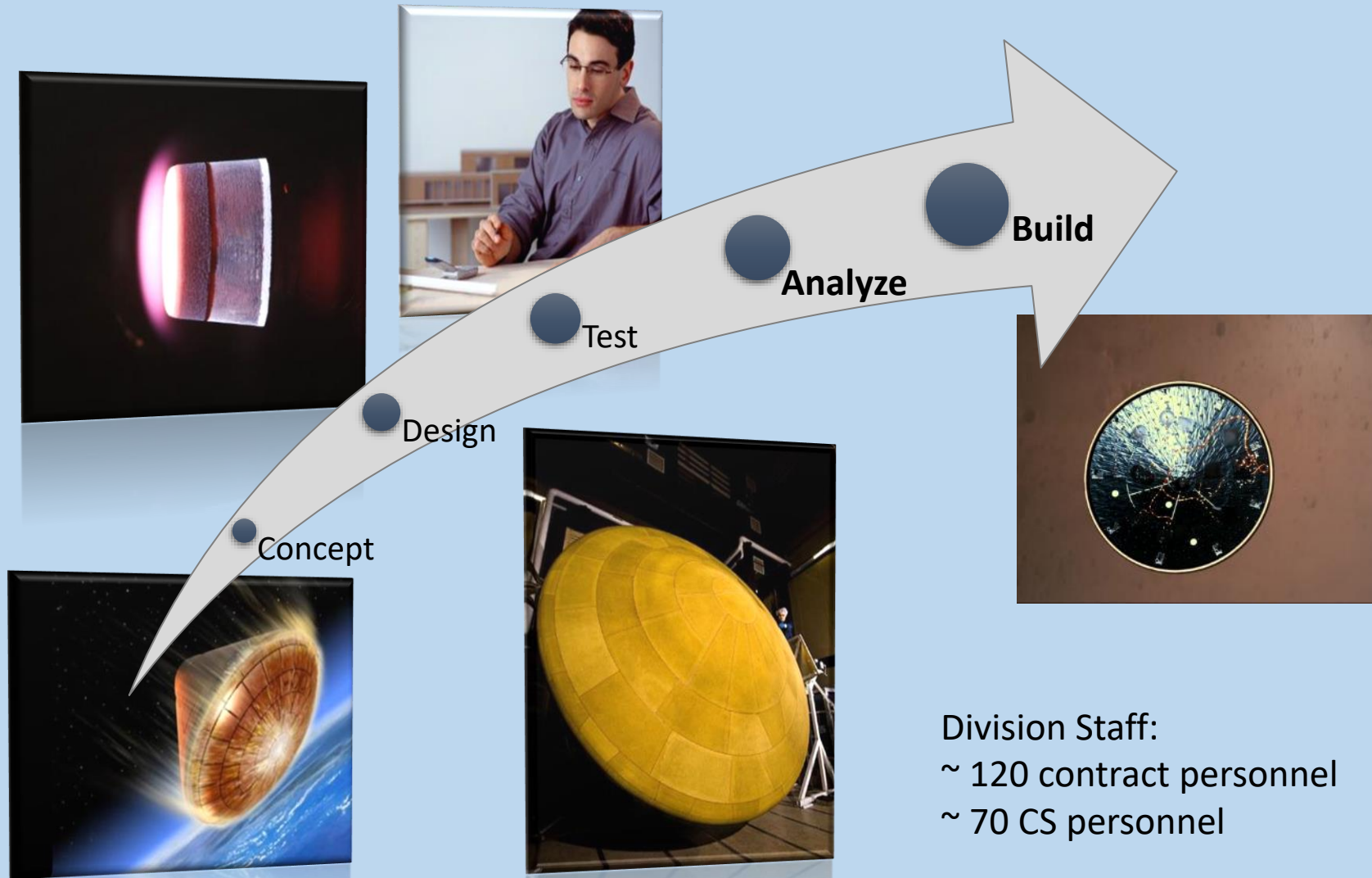

Division Staff:
~ 120 contract personnel
~ 70 CS personnel



Thermophysics Facilities Branch Entry Systems & Technology Division

- The Branch supports the Division for TPS design, materials development, thermal modeling, and TPS verification
- TSF operates, maintains, and improves
 - the Arc Jets (N234, N238)
 - Ballistic Ranges (N237 and N204A)
 - and Electric Arc Shock Tube (N229)
 - TSF supports the Planetary Aeolian Laboratory as required.

Ground testing for TPS design element validation

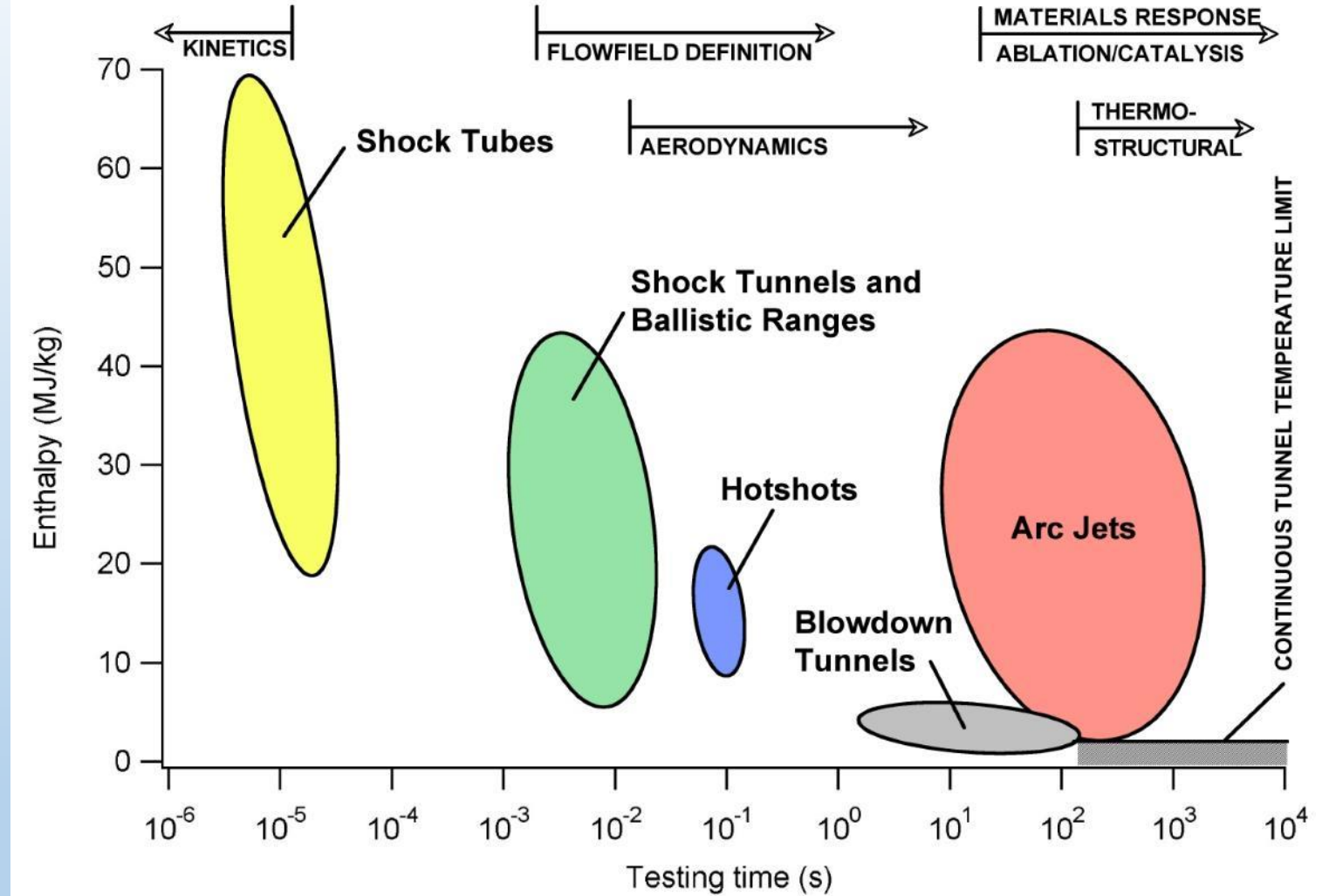

- No single facility can replicate ALL flight conditions
- Arc jets provide sustained aerothermal conditions for TPS validation

Objectives

- **Provide Aerodynamic heating**
 - Compression from shock wave ($T > 13,500^{\circ} \text{ F}$)
 - Radiation from shock layer
 - Surface friction
- **Provide representative pressures and gas composition**
- **Provide close match to boundary layer edge temperatures and structure**

We're Talking Heatshields

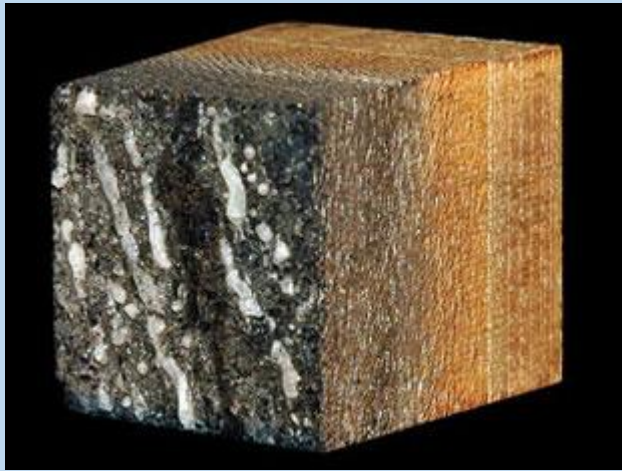

Mercury

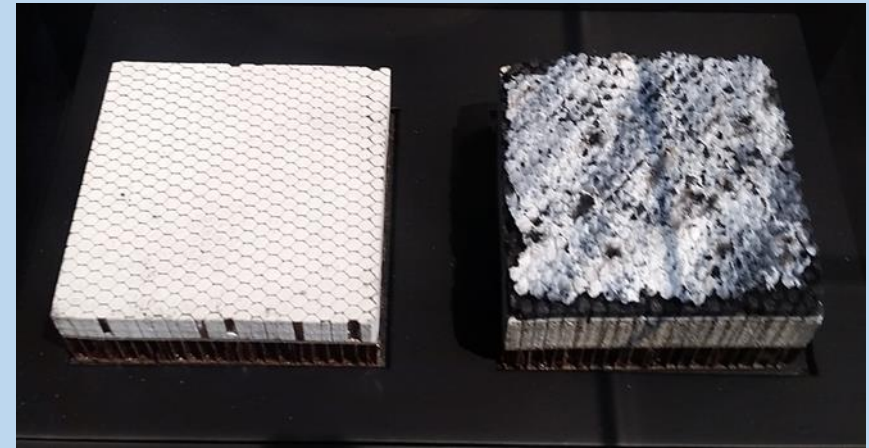

Gemini



Apollo Avcoat

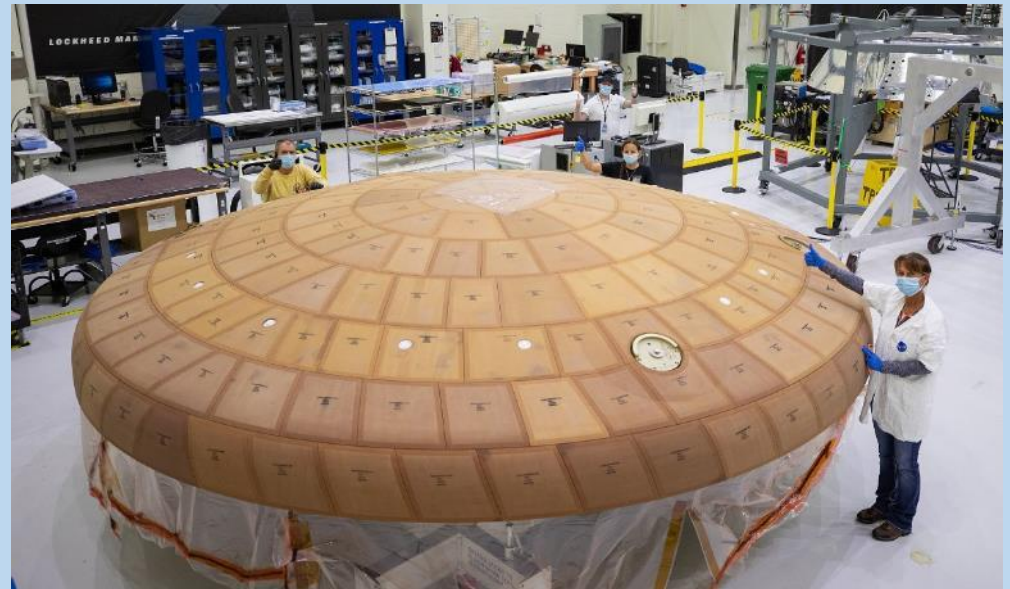

Orion Artemis II

Proving the System – Arc Jet Testing



An arc jet produces an electrically heated, high speed gas flow projected onto a test article – matching key parameters of high-speed entry from space into an atmosphere



How it works

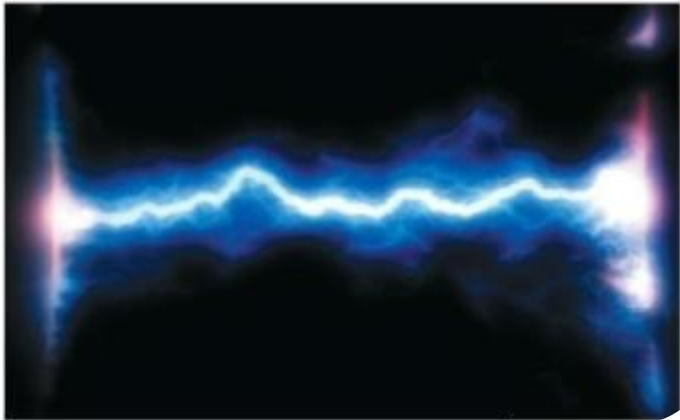

- ▶ Under vacuum, add argon gas; connect a hi-voltage car battery across electrodes to breakdown argon; and we have a flow of electrons inside the arc jet tube.
- ▶ Air flow collides with electrons in this “lightening bolt” → dissociated air at high temperatures ($> 9000^{\circ}\text{F}$)
- ▶ Expand dissociated air out a nozzle to hypersonic conditions and into a chamber at altitude conditions matching peak heating
- ▶ When conditions are correct, insert test sample and see what happens!

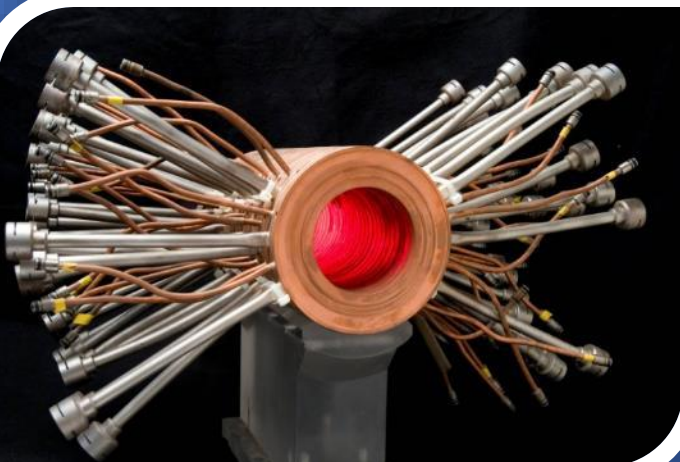

Arc Jet Complex @ Ames



Power supplies: 150 MW & 20 MW continuous
Steam Vacuum System: 10 lbs/sec, 0.1 psi
Steam Generator: 250 000 lbs/hr
Approximately 1.5 mi pipe/ductwork

Not pictured:

- Arc heater coolant circulation: 12 500 gpm
- High pressure air storage; 1.2M CF
- Independent 20 MW power supply
- Control and isolation systems

1 MW = 750 homes = 1340 hp

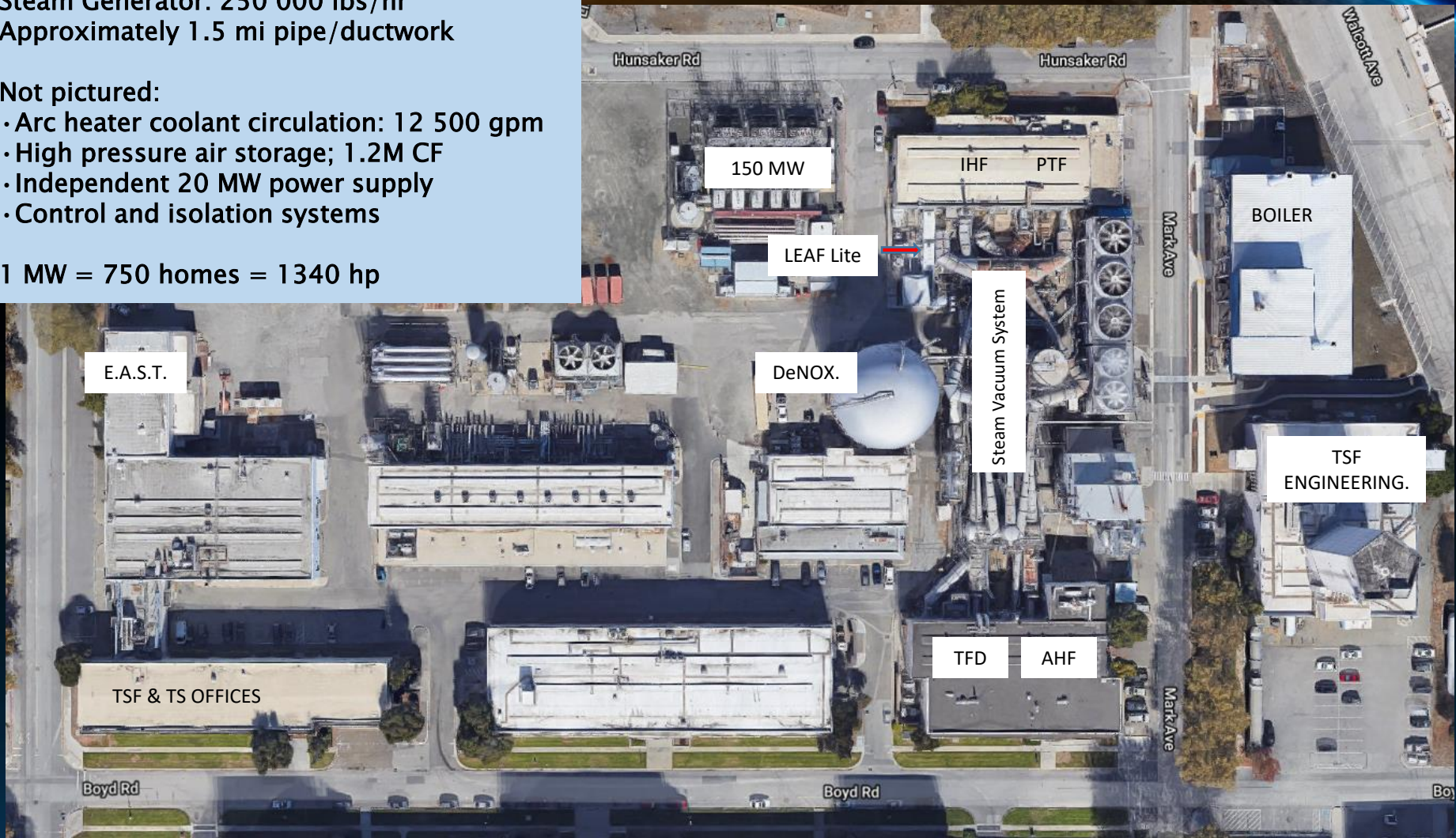

Simulation Envelope for Ames Arc Heated Wind Tunnels

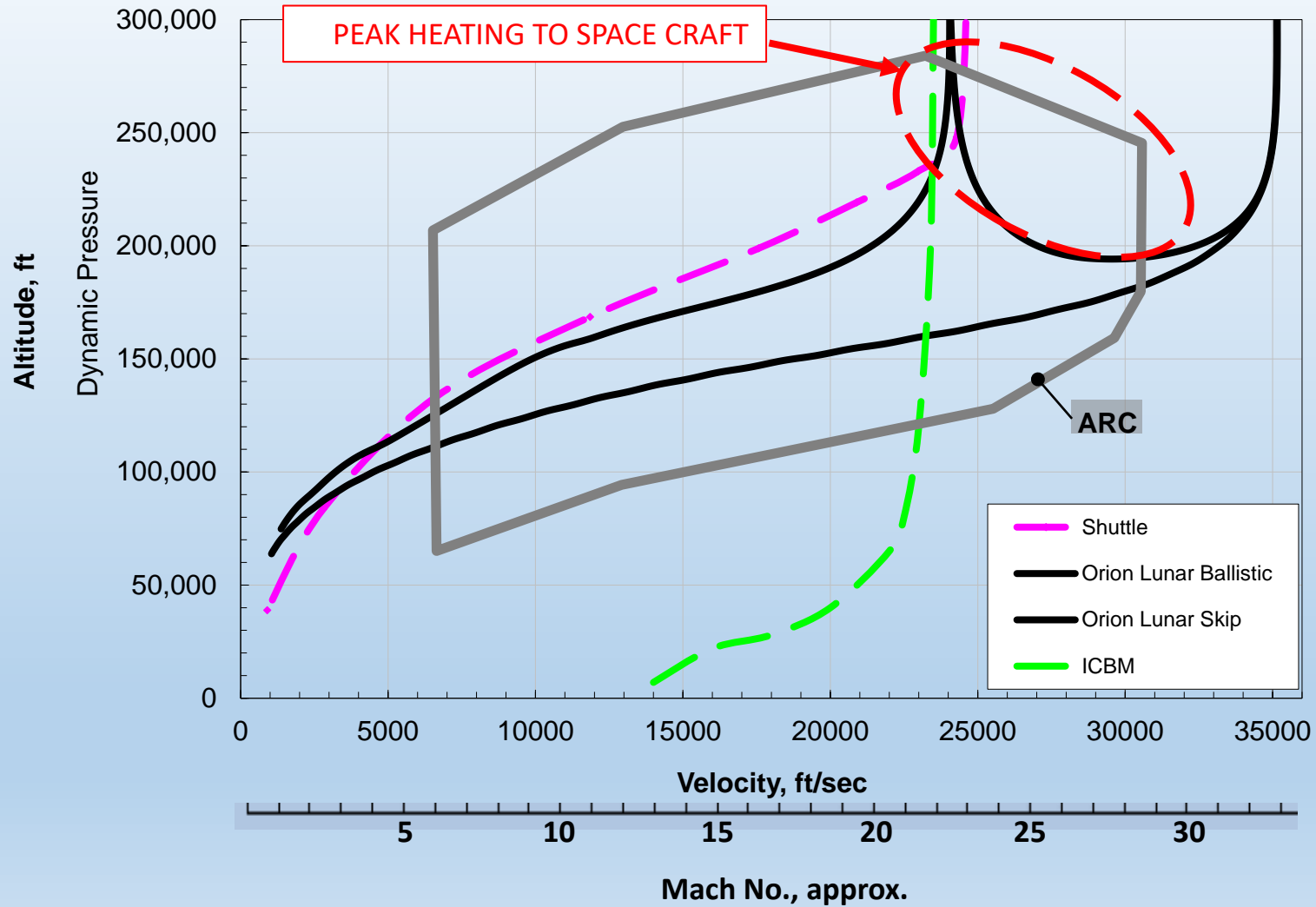



Facility Characteristics

- **High power, 5 operational arc jets** (10 MW, 14 MW, (2) x 20 MW, (1) x 60 MW)
- **Large test articles** (up to 60 x 60 cm flat panel, 30.5 cm diameter stagnation)
- **Continuous high enthalpy flows** (2 - 40 MJ/kg in air)
- **Spectroscopic, Photogrammetric Recession, and LIF flow diagnostics available**
- **Test times from seconds to over one hour**
- **Large range of trajectory matching**
- **Laminar and turbulent flows**
- **Return of combined heating capability**
- **Tests with air, nitrogen, oxygen and carbon dioxide. Hydrogen & helium in past**
- **Shared utilities (water, power, gas, etc.)**
- **Instrumentation:** pyrometers, IR camera, photogrammetric recession, video, scanning radiometer, thermocouples, pressure xducers, absorption spectroscopy

Interaction Heating Facility

- 60-MW power (highest in NASA)
- Enthalpy from 7 to 47 MJ/kg
- Stagnation pressure from 1000 to 600000 Pa
- Nozzles size from 7.5 to 104 cm dia.
- Sample size up to 30-cm diameter
- Semi-elliptic nozzle for flat samples up to 60 cm by 60 cm

Panel Test Facility

- 20-MW power
- Enthalpy from 7 to 35 MJ/kg
- Surface pressure 60 – 5000 Pa
- Semi-elliptic nozzle 10 cm x 43 cm exit
- Flat samples up to 40 cm by 40 cm

Aerodynamic Heating Facility

- 10 and 20-MW power
- Enthalpy from 1 to 35 MJ/kg
- Stagnation pressure 500 to 15200 Pa
- Nozzles size from 17.8 to 91 cm
- Sample size up to 20-cm diameter
- 5-arm insertion system for maximum testing efficiency
- Gases: air, Nitrogen, Oxygen, CO₂

Turbulent Flow Duct

- 12-MW power (Huels heater)
- Enthalpy from 3 to 9.4 MJ/kg
- Surface pressures 2000 to 15000 Pa
- Fully turbulent supersonic flow
- Nozzle exit 5 x 22.8 cm
- Sample size 20 x 25 cm or 20 x 50 cm
- Shear levels 47 – 720 Pa
- Gases: air and Nitrogen

Types of Arc Heaters at Ames

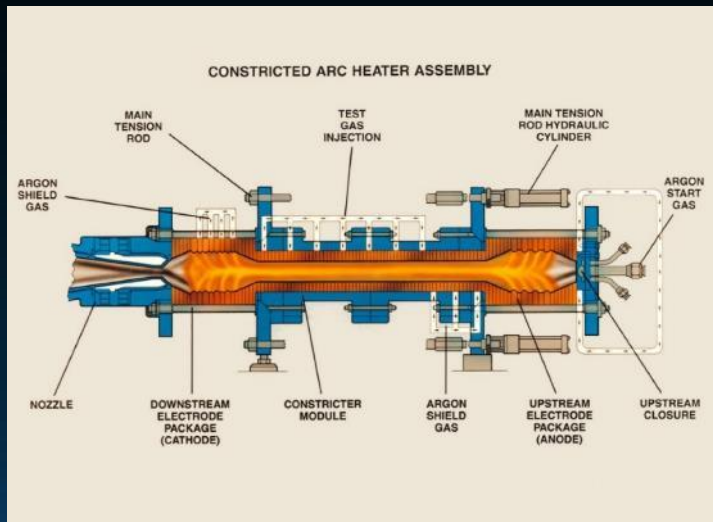
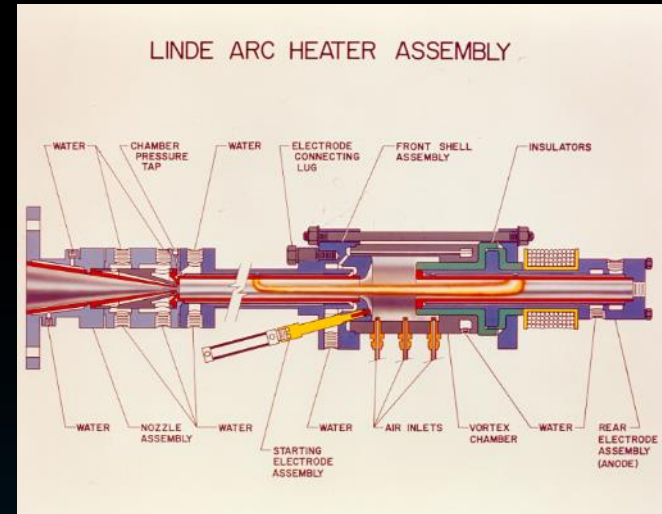
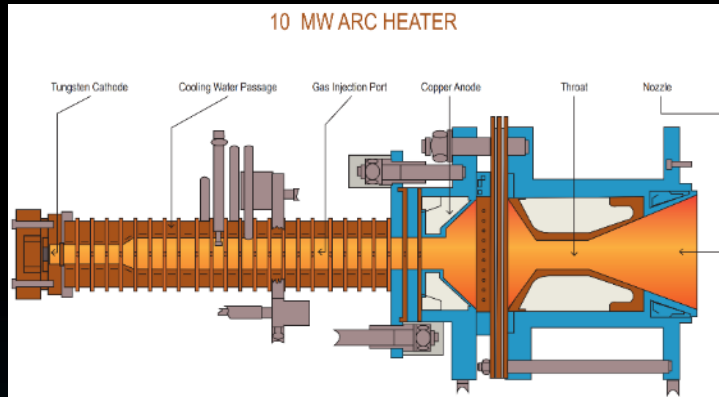

NASA AMES ARCJET COMPLEX



Aerodynamic Heating Facility
10 & 20 MW - TPS Free Jet Testing

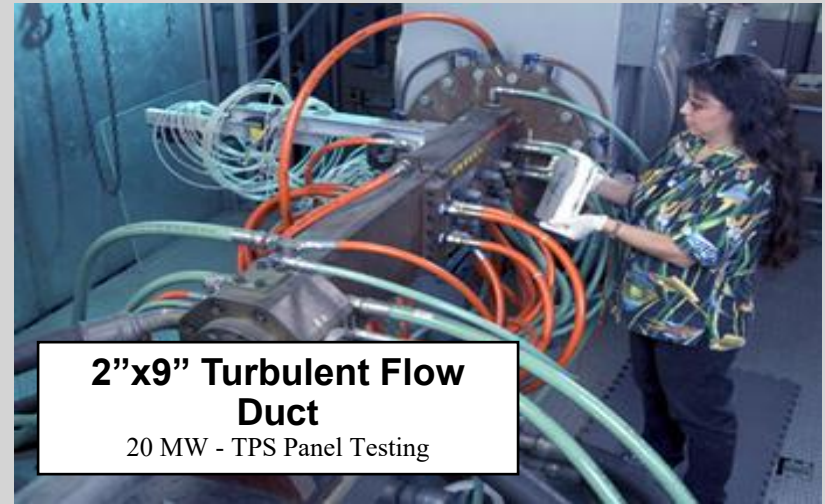

2''x9'' Turbulent Flow Duct
20 MW - TPS Panel Testing



Panel Test Facility
20 MW - TPS Panel Testing



Interaction Heating Facility
60 MW - TPS Free Jet and Panel Testing

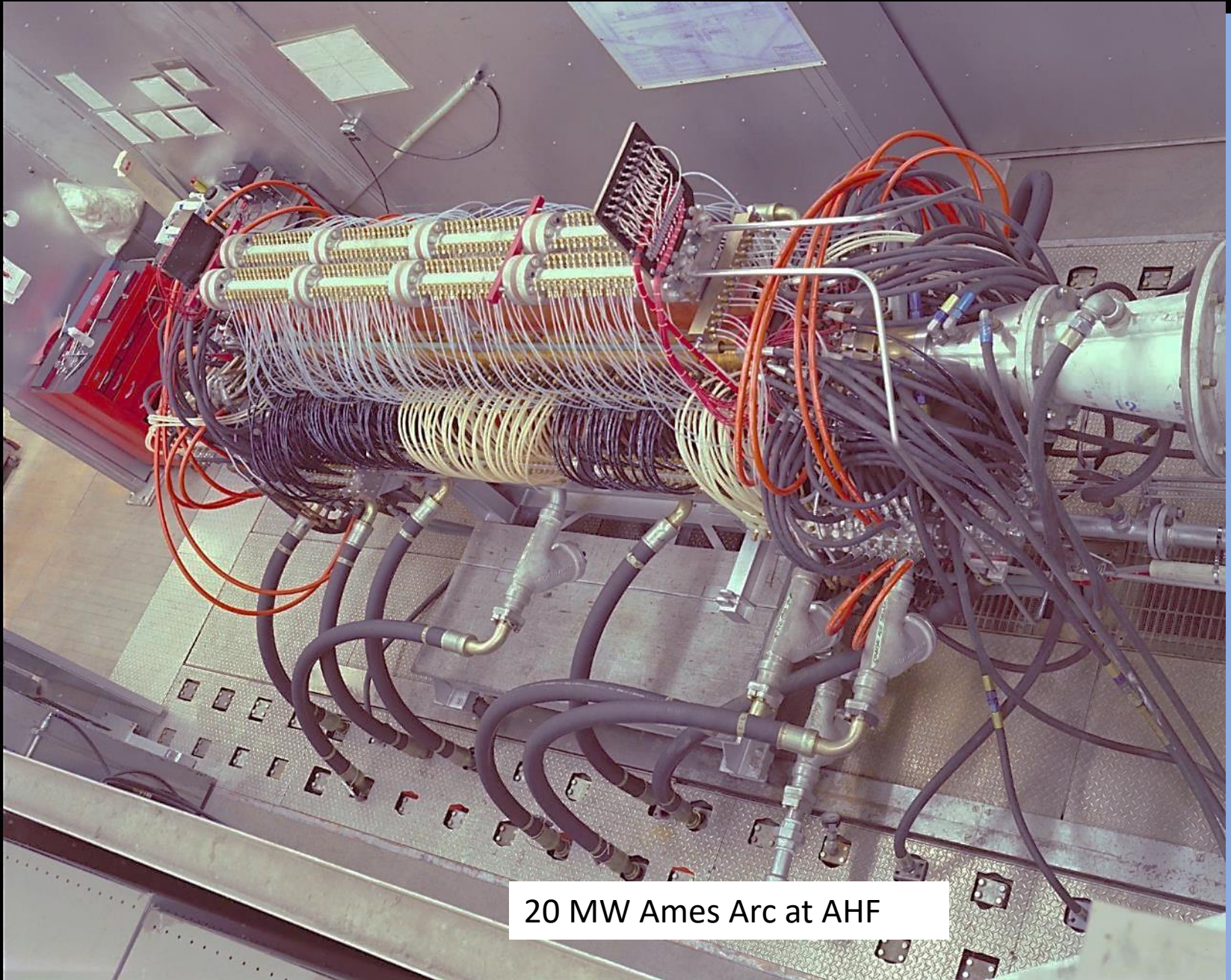

20 MW Ames Arc at AHF

Panel Test Facility



Interaction Heating Facility

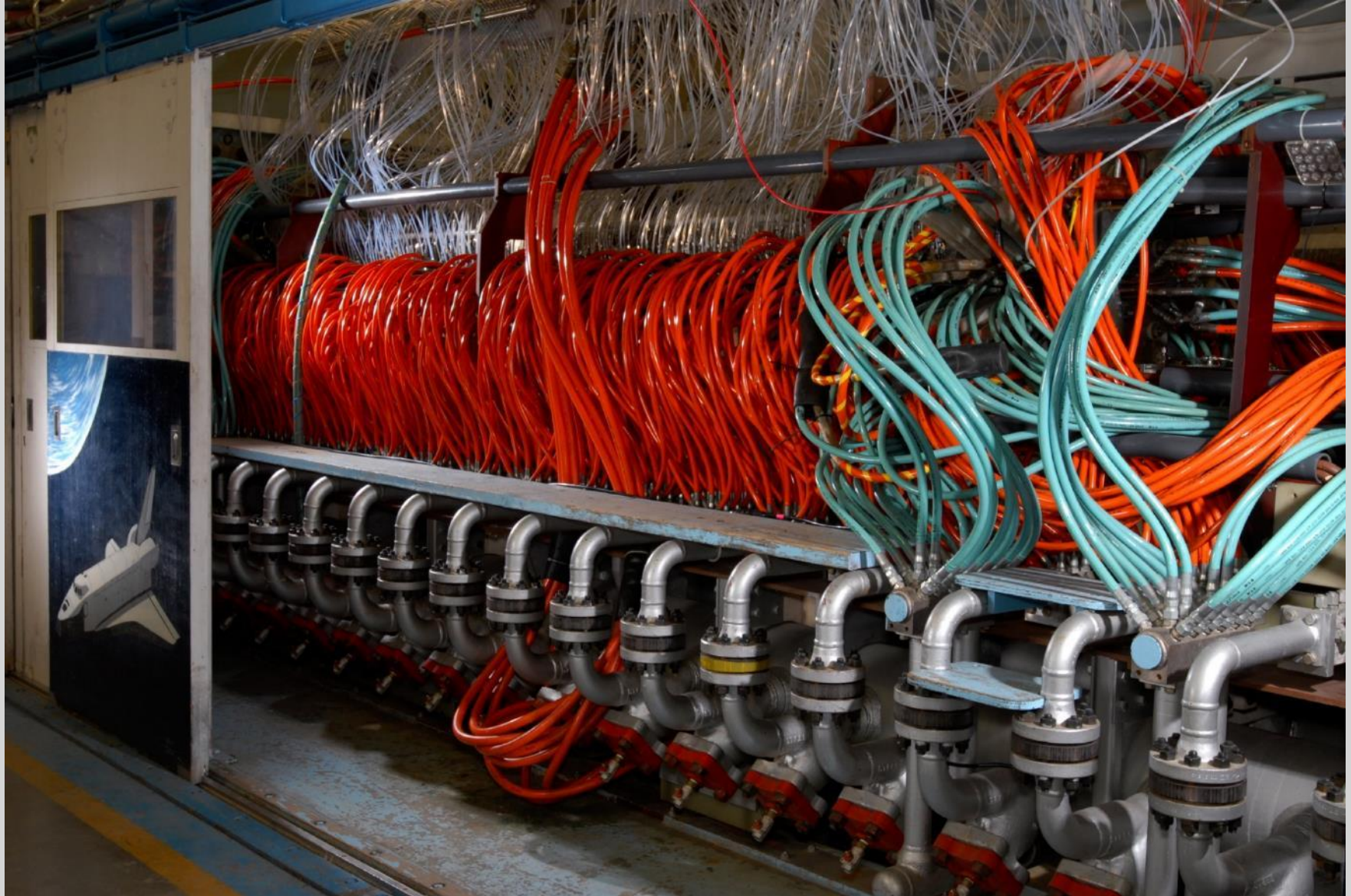

The rest of us



Radiative Heating @ Ames

- 4 ea. 50-kW fiber laser units from IPG Photonics
- 1070nm wavelength (ytterbium)
- Produces 6 x 6" and 17 by 17" flat top and Gaussian (~4" circular)
- Calibration plates and burn plates, 30 kW Ophir power meter
- Ames AJC only facility to do combined convection and radiative heating

Combined convective and radiative heating

- Laser Enhanced Arc-jet Facility (LEAF-Lite)
- Interaction Heating Facility
- LEAF-Lite allows for combined radiative and convective testing

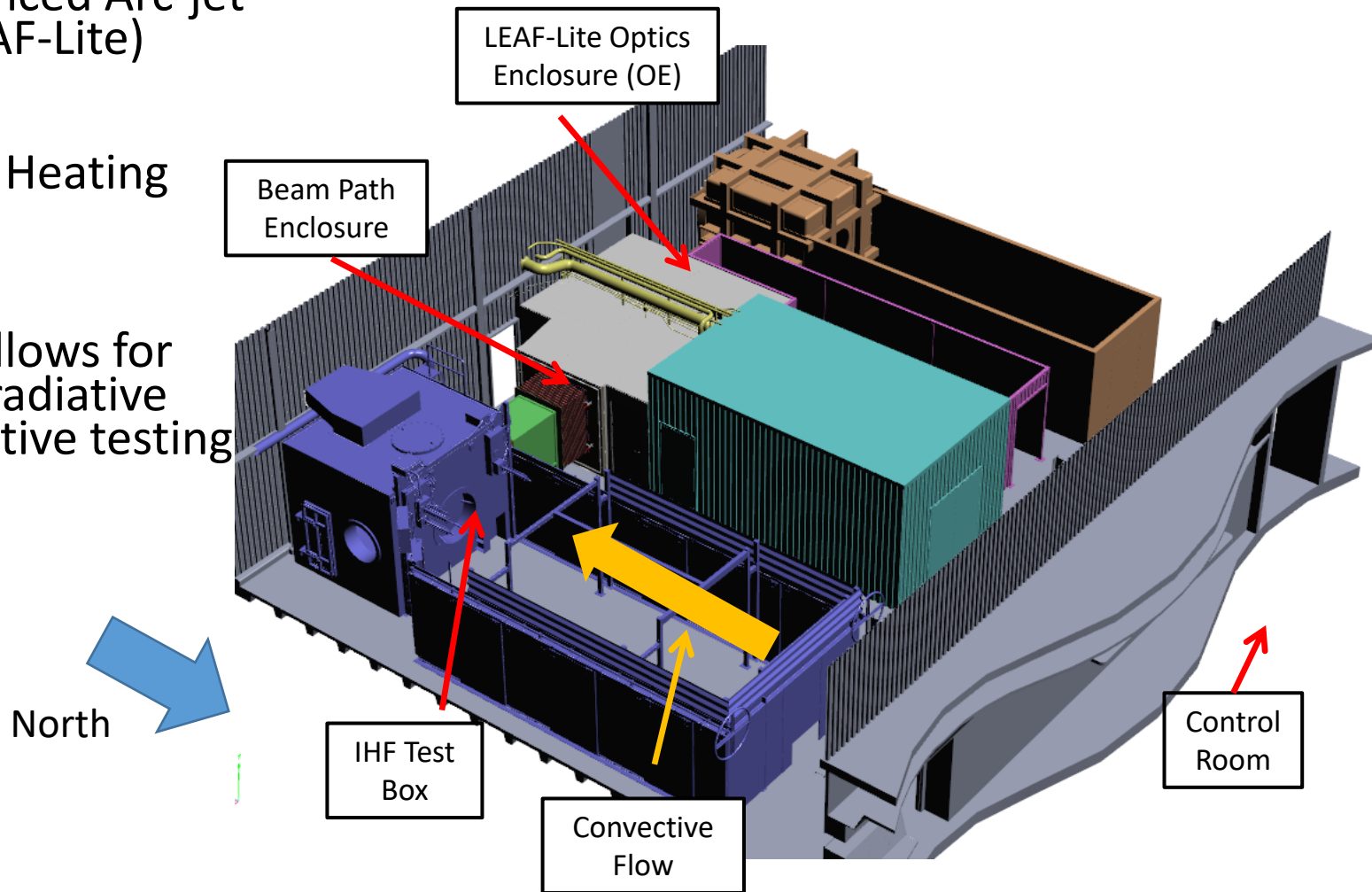

Beam Delivery

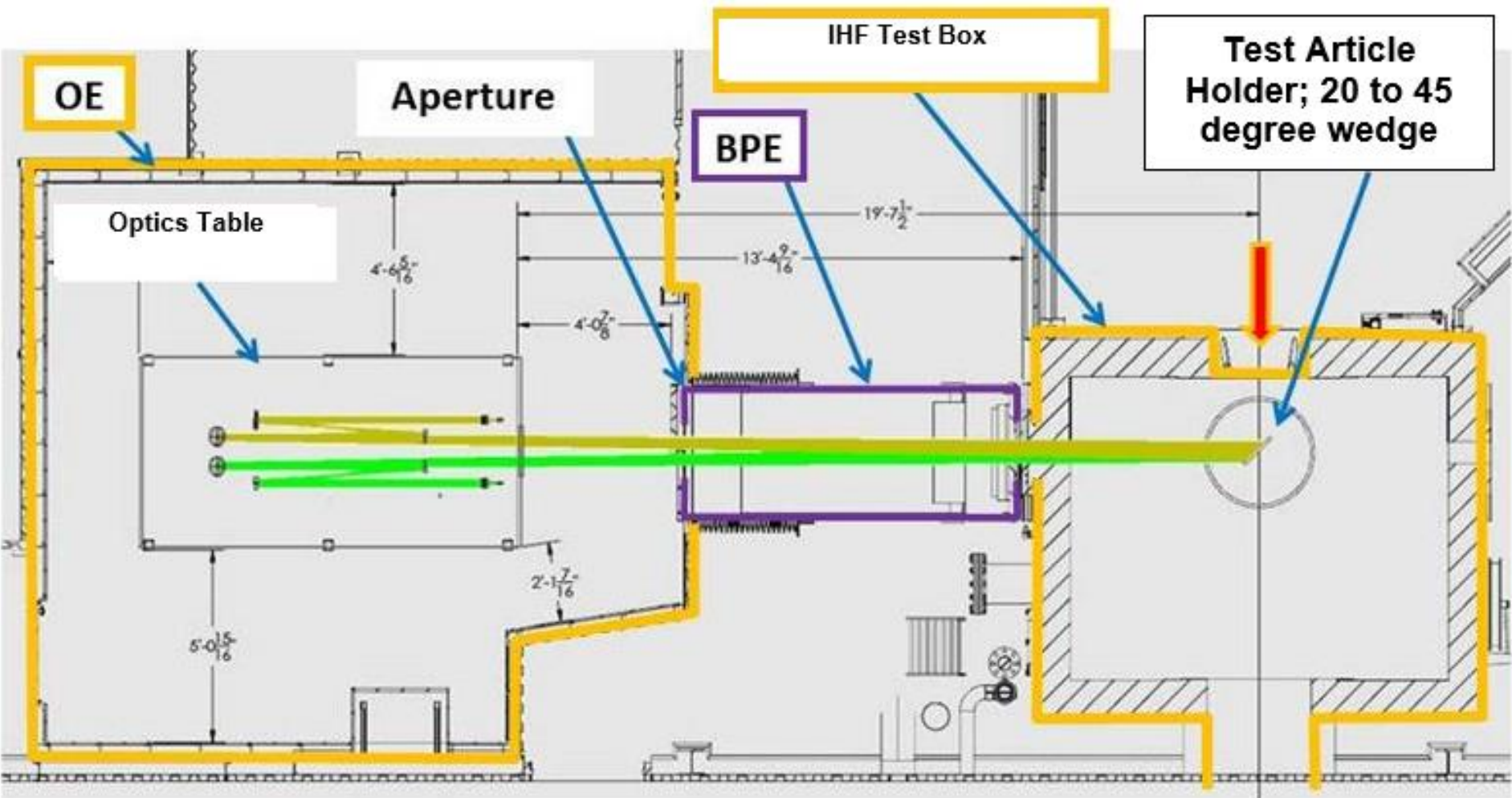

Ames Vertical Gun Range



PURPOSE: Study the physics of high-speed impact and crater formation processes.

PERFORMANCE SUMMARY:

- Projectile speed 0.5 to 7.0 km/sec
- Projectile size* 0.005 mm to 7.6 mm
- Projectile geometry sphere, cylinder, irregular shapes
- Projectile composition metallic, plastic, glass, mineral
- Test section environment variable (Air, CO₂, etc.)
- Test section pressure 5 to 1013 Pa
- Test section temperature Ambient

TEST CHAMBER DIMENSIONS:

- Diameter 2.5 m
- Height 2.5 m
- Volume 14 m³

* Individual particles: 1.5 to 7.6mm; group of three 0.2 to 1.0mm; and cluster of many 0.005 to 0.2mm.

Ejecta Dispersion Analysis and Capture

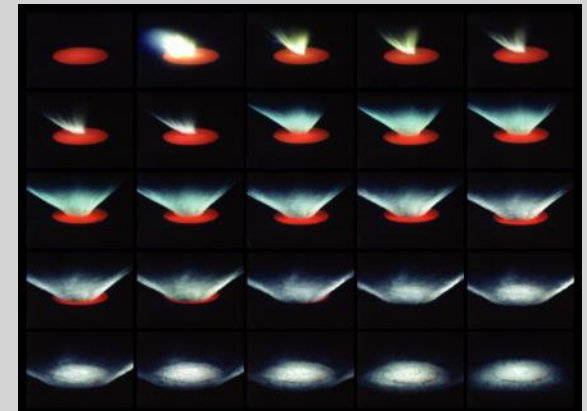

Ames Vertical Gun Range



Hypervelocity Free-Flight Aerodynamic Facility



HFFAF Data Gathering Systems:

Trajectory & Aerodynamic Coefficients:

Type:	Focused shadowgraph (film-based)
Light Source:	Spark gap (capacitive discharge)
Shuttering:	Kerr cell (electro-optical), 40 ns exposure
Model Detection:	Photomultiplier-tube/halogen light sheet

Aeroballistic Models

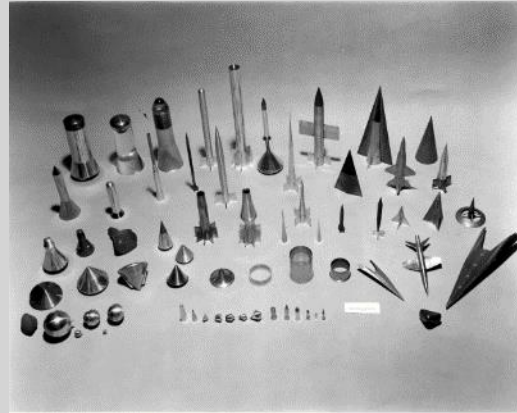

MSL Shadowgraph

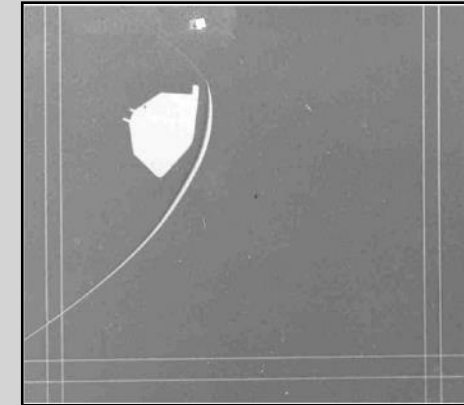

Model Launching Gun (Light-Gas & Powder)

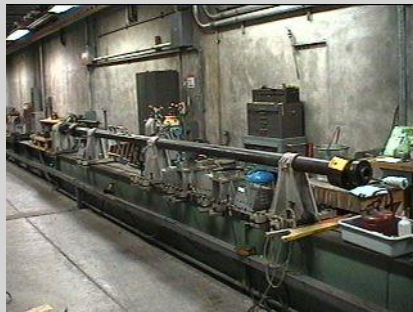

Sabot Separation Tank



Test Section (Shadowgraph Stations)



Test Section (Interior)



National Aeronautics and
Space Administration

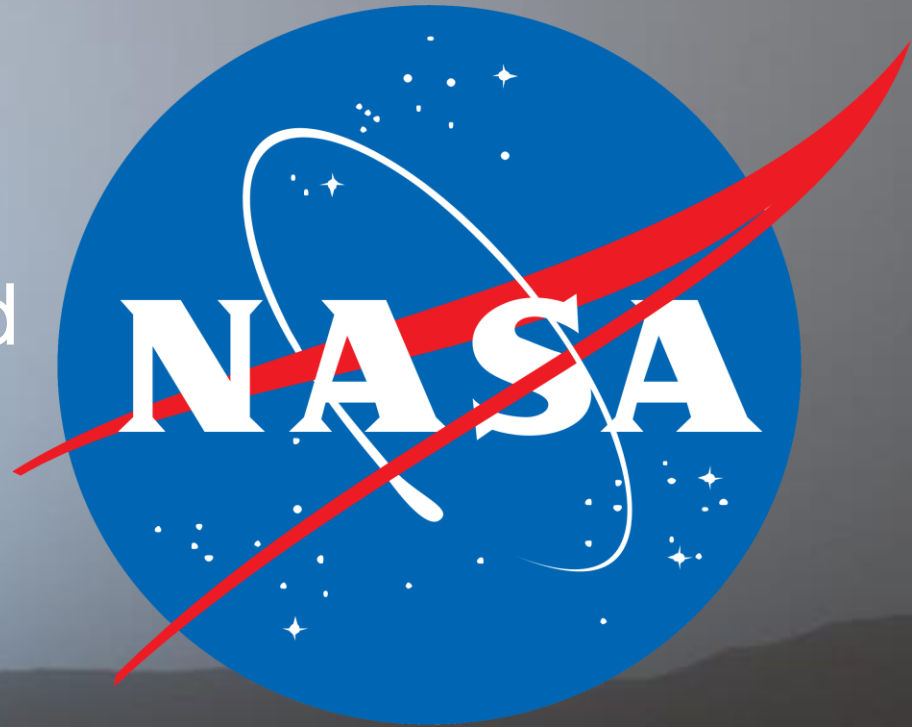

Ames Research Center
Entry Systems and Technology Division

Visit us at <https://www.nasa.gov/centers/ames/thermophysics-facilities-home>

Sunset on Mars – NASA/JPL MSL

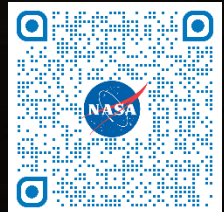



SILICON
VALLEY

AMES RESEARCH CENTER

Extra Sides

Early Developments at Ames

- Harvey Allen blunt body concept
- Separate facility for arc jets ~ 1962
- Patent on segmented constrictor arc heater '68
- 60-MW arc heater for Shuttle ~ 1974

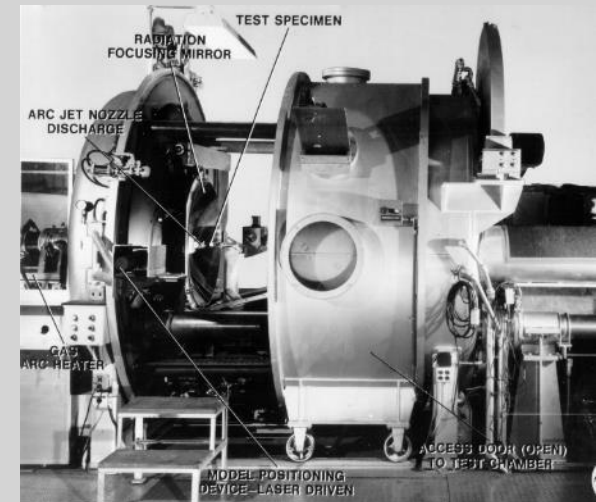
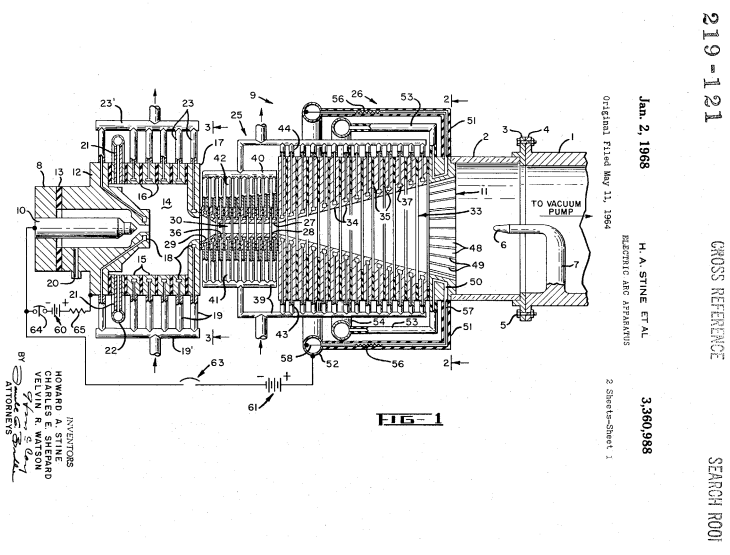

NASA Ames Entry Systems Inventions

Advanced Entry Heating Simulator

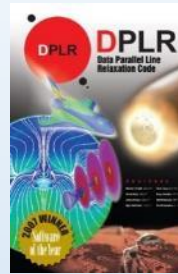
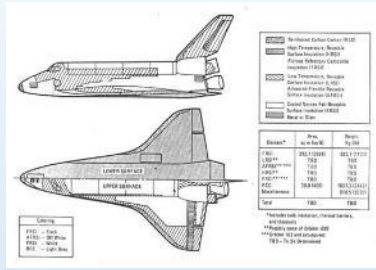
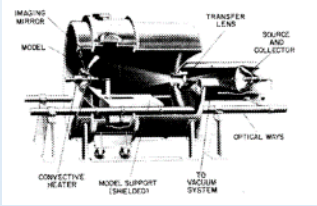

ADEPT



Constricted Arc Heater

RCG
LI-2200
FRCI
AFRSI
AETB
TUFI

SIRCA

TUFROC

3DMAT

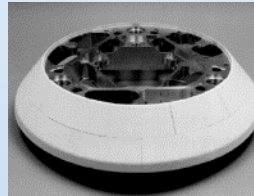
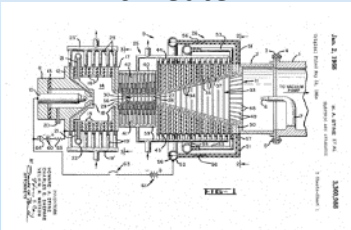

1960

1970

1980

1990

2000

2010

HEEET

2020

Blunt Body Concept* (1951)

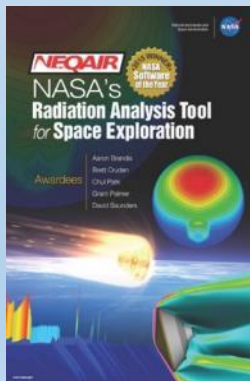
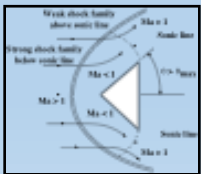

PICA



FIAT

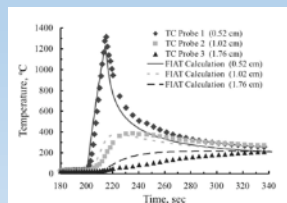

Laser-Enhanced IHF

