

# Spaceborne Laser Transmitter Development for the Laser Interferometer Space Antenna (LISA) Mission

Anthony W. Yu  
NASA Goddard Space Flight Center  
16 JUNE 2020

Presentation to the NESC Academy

# Outline

- Introduction and LISA Requirements
- NASA Laser Architecture
- NASA Laser Activities for LISA
- Laser Maturation, Risk Mitigation and Reliability Test Plans
- Test Capabilities
- Summary

# INTRODUCTION

# Gravitational waves

- Emitted from super-massive objects
  - New way to observe universe
    - E.g. Black hole binary (GW150914, etc.), neutron star binary (GW170817)
  - Causes distance change between free masses (objects)
    - Detection by laser interferometer
    - Differential strain between two orthogonal directions

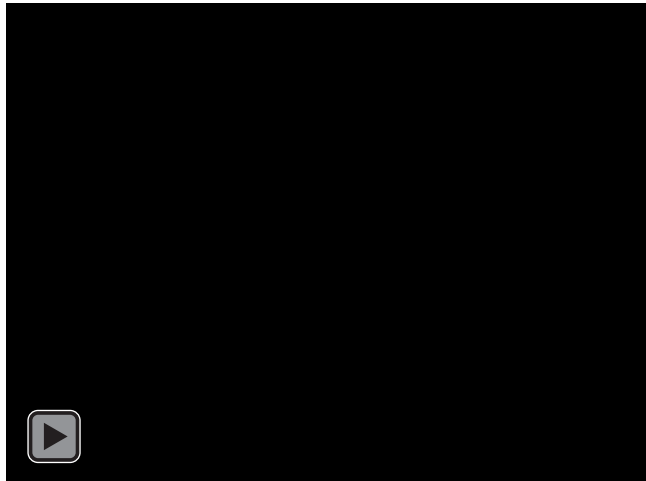

# Gravitational wave detection

- Size of strain  $h$ 
  - $h \sim 10^{-21}$  for typical GW source
  - $L \sim 2.5 \times 10^6 \text{ km}$  (LISA):  $L * h \sim 1 \text{ pm}$
- LISA (Laser Interferometer Space Antenna)
  - ESA (European Space Agency)-led mission,  $\sim 2034$  launch
  - Displacement measurement between “free” masses
    - Concept validated by the LISA pathfinder mission
  - Laser system
    - Candidate US (NASA) component contribution

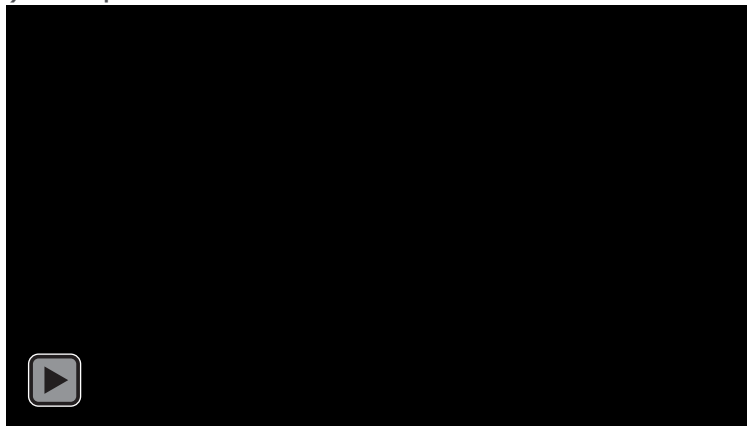
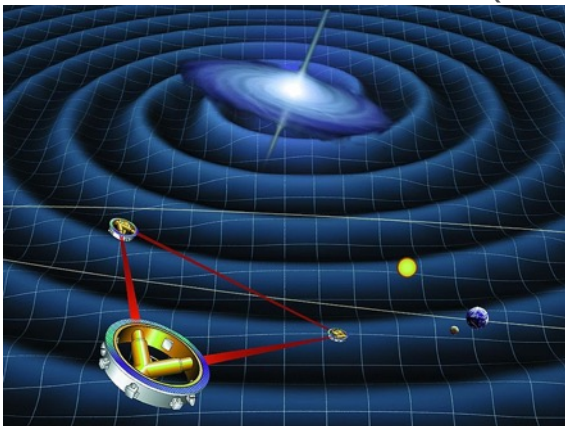
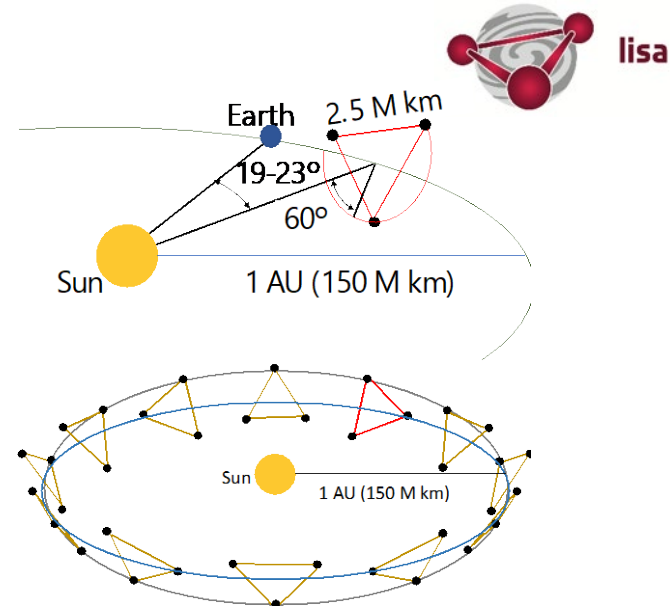

# LISA measurement system

- **Heterodyne interferometer**
  - Two phase-locked lasers
    - “Amplifying mirror”
    - Phasemeter with internal PLL
      - Changing Doppler shift frequency
    - Phase locker with  $\sim \mu\text{cycle}$  accuracy
      - Shot noise limited operation
  - Split interferometry
    - 3 interferometers to measure 1 DoF

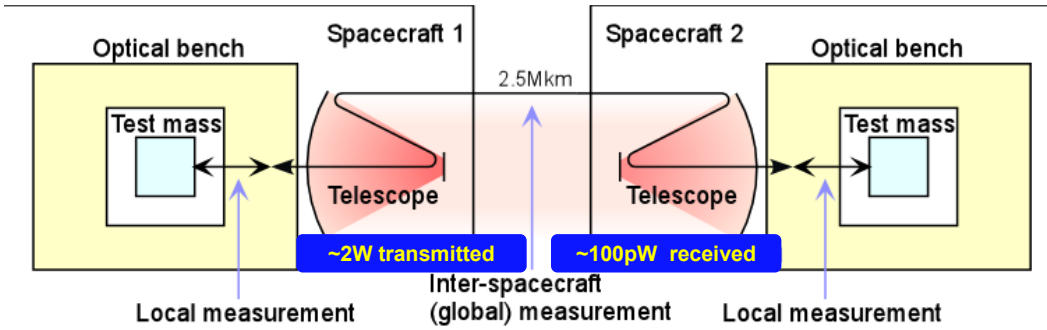
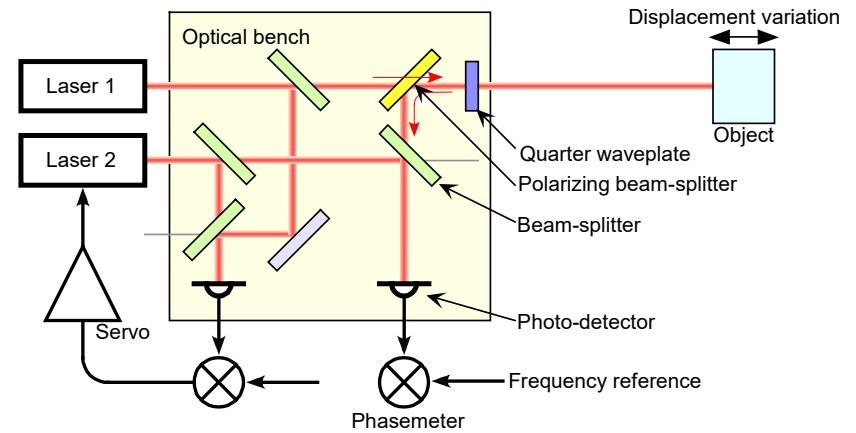

# Laser Systems for LISA and Redundancy Strategy

- ❑ Each Spacecraft (SC) has one laser system (LS)
  - Each LS has two Laser Assemblies (LA) and one Laser Pre-Stabilization System (LPS)
  - Each LA has two Laser Heads (LH) - one hot and one cold redundancy
    - 4 LH per SC, 12 in the constellation.
  - Each LH comprises a Laser Optical Module (LOM) and Laser Electrical Module (LEM)
    - LOM is a MOPA laser with one MO and one PA
    - 1 Laser is the master and the remaining 5 are transponders.
  
- ❑ One Laser Pre-stabilization System (LPS) per S/C
  - Redundancy at constellation level (3 in the constellation)

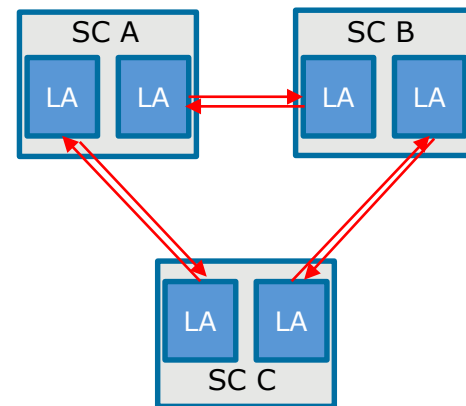
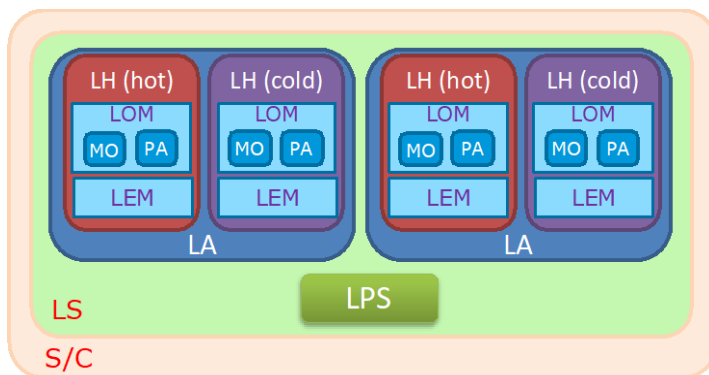

# Architecture & Requirement

## Master Oscillator Power Amplifier (MOPA)

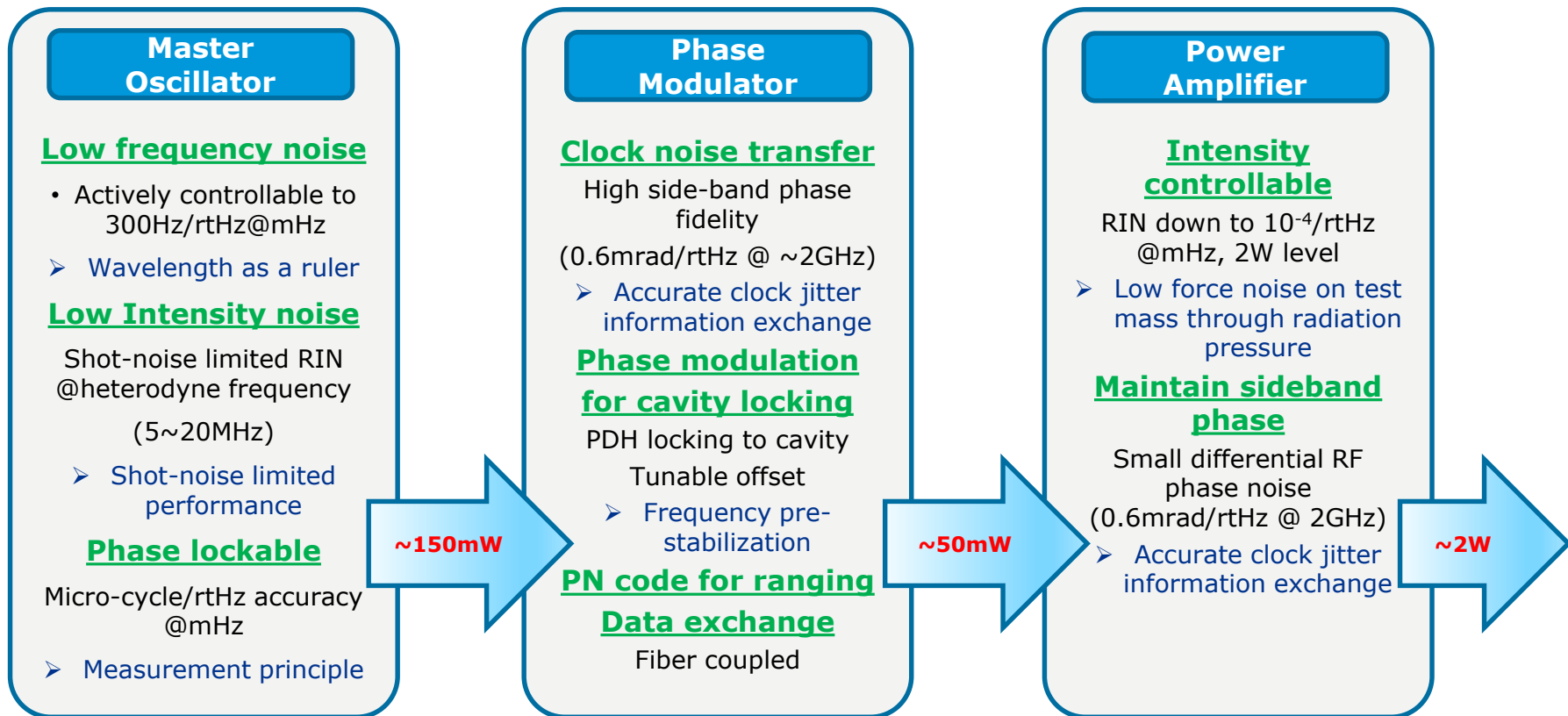

# High Level Requirements



- Dimensions 250x250x200mm per LH\*.
- Mass 12kg per LH\*
  - Volume and mass allocations to be spread between sub-units (LOM and LEM).
- LS dissipated power <75W (TBR)
- LS OP temperature  $20 \pm 10^{\circ}\text{C}$  (TBR)
- LS NOP temperature  $-20^{\circ}\text{C}$  to  $+50^{\circ}\text{C}$  (TBR)
- LEM interfaces TBD depending on concept.
- >2W on OB at EoL
- Polarisation linear (S TBC)
- Few mW pick-off for Laser Pre-stabilization System (LPS)
- Lifetime >16 years (including ground testing, cruise, normal & extended science ops)
- Wavelength 1064.49nm

*\*for LH only, does not include LPS*



# NASA LASER ARCHITECTURE

# Top Level Comparisons Between LISA and Previous/Current Missions

	Previous Missions @ GSFC	LISA
Type of Measurement	Altimetry	Measure changes in interferometer arms length
Method of Measurement	Direct TOF Range Measurement	Interferometric Distance Measurement
Laser Spectral Req't	Center Wvlgh/Rcv'r filter match, Single or Multi mode laser	Frequency stabilized, single frequency laser source
Maximum Range	Typically ~400 km for Earth LEO; MLA Achieved 24 M-km Ranging	Arm of an interferometer $2.5 \times 10^6$ km
Laser Architectures	Pulsed Q-Switched MOPA Laser	Continuous-wave MOPA Laser
Output Power	Average Power ~4W* Peak Power 30 MW*	Average Power per laser ~2W
Master Oscillator	Side pumped Cr:Nd:YAG slab with discrete components	End Pumped Cr:Nd:YAG in monolithic resonator
Power Amplifier	Side Pumped Nd:YAG slabs	Fiber based amplifier
Pump Diodes	Quasi-continuous wave, high peak power laser diode arrays, 100 W peak per bar at 808 nm and 885 nm	Continuous wave pump diodes with average power in the few Watts range at both 8XX nm and 9XX nm
Lifetime	<ul style="list-style-type: none"> <li>• Typical 3 to 5 yrs</li> <li>• LOLA (launched Jan 2009) – still in operation for &gt;11 years</li> <li>• MLA (launched Aug 2004) laser – cruised for 7 years, operated for 4 yrs</li> <li>• CALIPSO (LaRC) (launched 4/2006) – still in operation for &gt;12 years</li> <li>• ICESat-2/ATLAS (launched 2018) - in operation</li> <li>• GEDI/HOMEER (launched in 2018) - in operation</li> </ul>	<ul style="list-style-type: none"> <li>• 16+ years including ground testing, cruise, normal and extended science operations</li> </ul>
Lessons learned	<ul style="list-style-type: none"> <li>• High peak fluence caused optical damage</li> <li>• Frequency conversion to shorter wavelength (higher photon energy) caused contamination induced damage(CID)</li> <li>• Evacuated enclosure (lasers operated in vacuum) – enhanced CID issue</li> <li>• Single string vendor for pump diodes</li> <li>• Lack of extended lifetest in early product lifecycle</li> </ul>	<ul style="list-style-type: none"> <li>• Use of CW laser, low average power to minimize probability of damage</li> <li>• No frequency conversion</li> <li>• Pressurized enclosure with clean dry air or equivalent</li> <li>• Multiple qualified vendors</li> <li>• Lifetest and qualify design as early as possible</li> <li>• Leveraging lasercom effort, which GSFC is leading the LCRD mission with a 2019 launch date</li> </ul>

# Combining GSFC Solid State Lasers and Fiber Lasers for Space Experiences

## Nd:YAG Lasers for Space

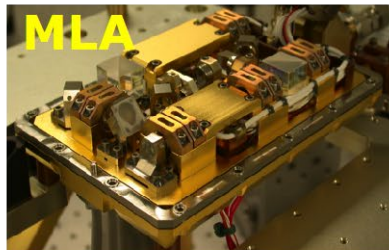
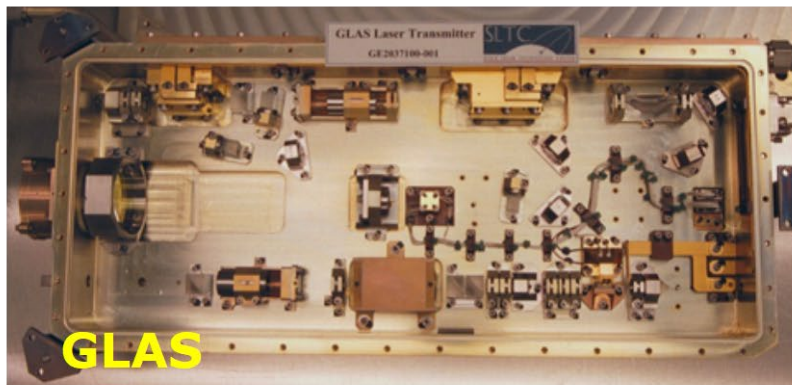

## Fiber Based Lasers for Space

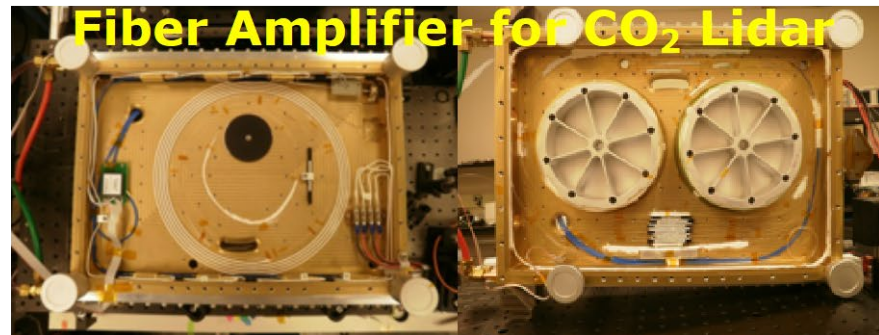
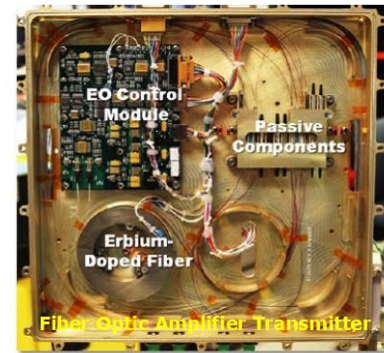
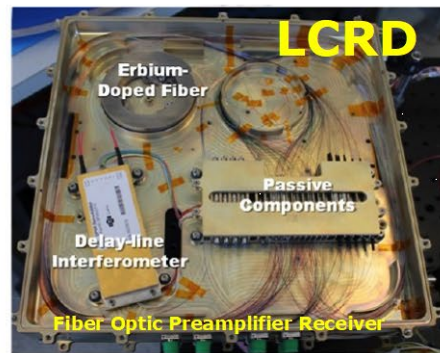



- ❑ The GSFC laser transmitter design for the LISA mission is based on the master oscillator (MO) power amplifier (MOPA) architecture and is the best technical path for meeting the LISA requirements
  - A MOPA architecture separates the problem: the MO dominates the frequency and phase noise, whereas RIN is usually associated with lasing at high power
  - High power means a large resonator, in which it is difficult to maintain resonator alignment, length, vibration of components that would lead to noise.
  - We choose to use a smaller, monolithic, lower power MO approach to minimize noise contribution.
  - Design the MO to meet spatial, spectral and temporal requirement except power
  - Use an optical power amplifier to scale the output
  - *This is consistent with the ESA approach for LISA as well as related systems such as LIGO and Advanced-LIGO*
- ❑ Modulator – depending on the MO design, the modulator could be a stand-alone subsystem or part of the MO package
- ❑ Power Amplifier – Single frequency, low noise power amplifier for power scaling of the MO. This may contain a pre-amplifier stage if higher gain is necessary, depending on MO output power level.

# Laser System for LISA – NASA design

- MOPA (Master Oscillator Power Amplifier)
  - MO (Master Oscillator)
    - Re-designed NPRO with small crystal:  $\mu$ NPRO package by AVO Photonics
    - 2 MOs / 1 LOM box (cold redundant), 2 LDs / 1 MO (hot redundant)
  - *Single stage Power Amplifier (PA)*
    - Forward pumped DC gain fiber: PA module by Fibertek
    - 3 LDs / 1 PA (hot/cold redundant)

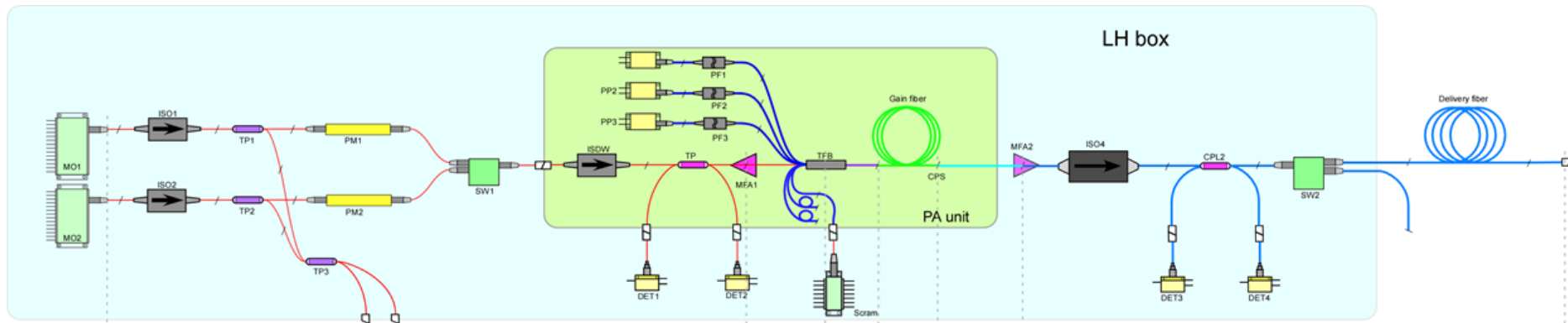

# Laser Optical Module (LOM)

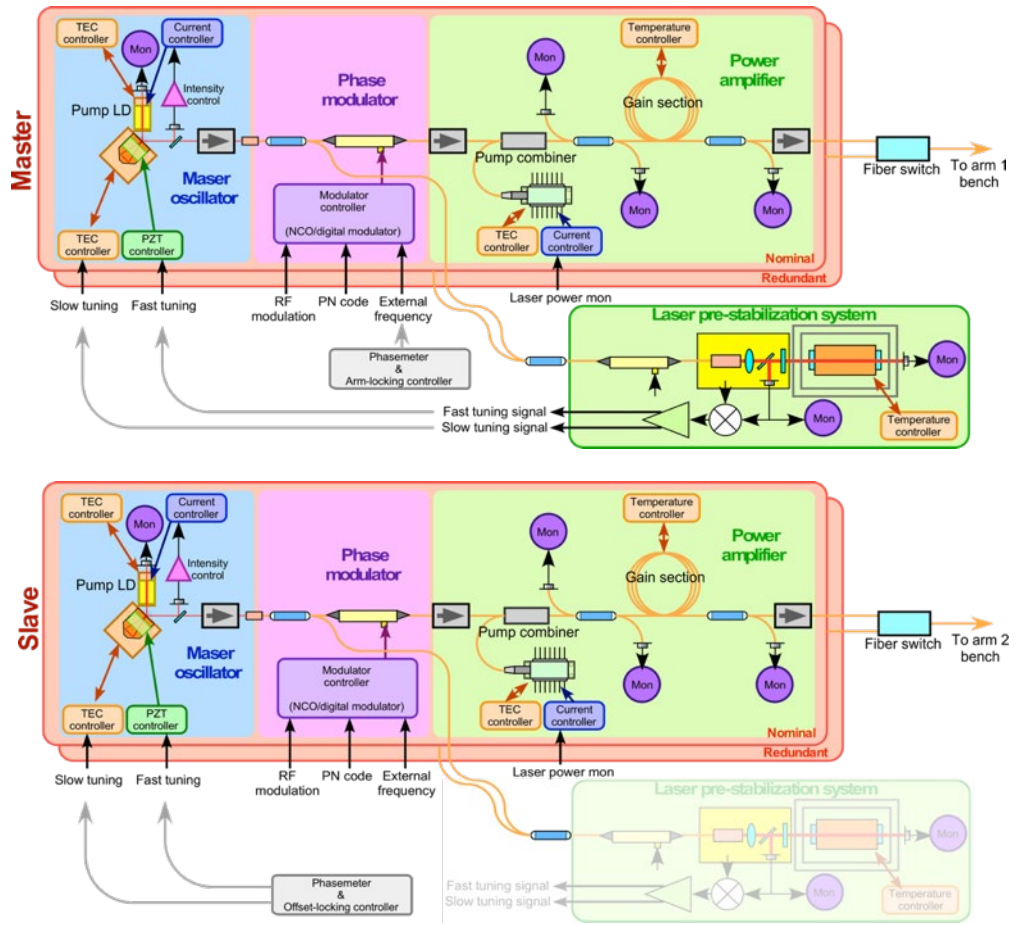

# Laser System with LEM

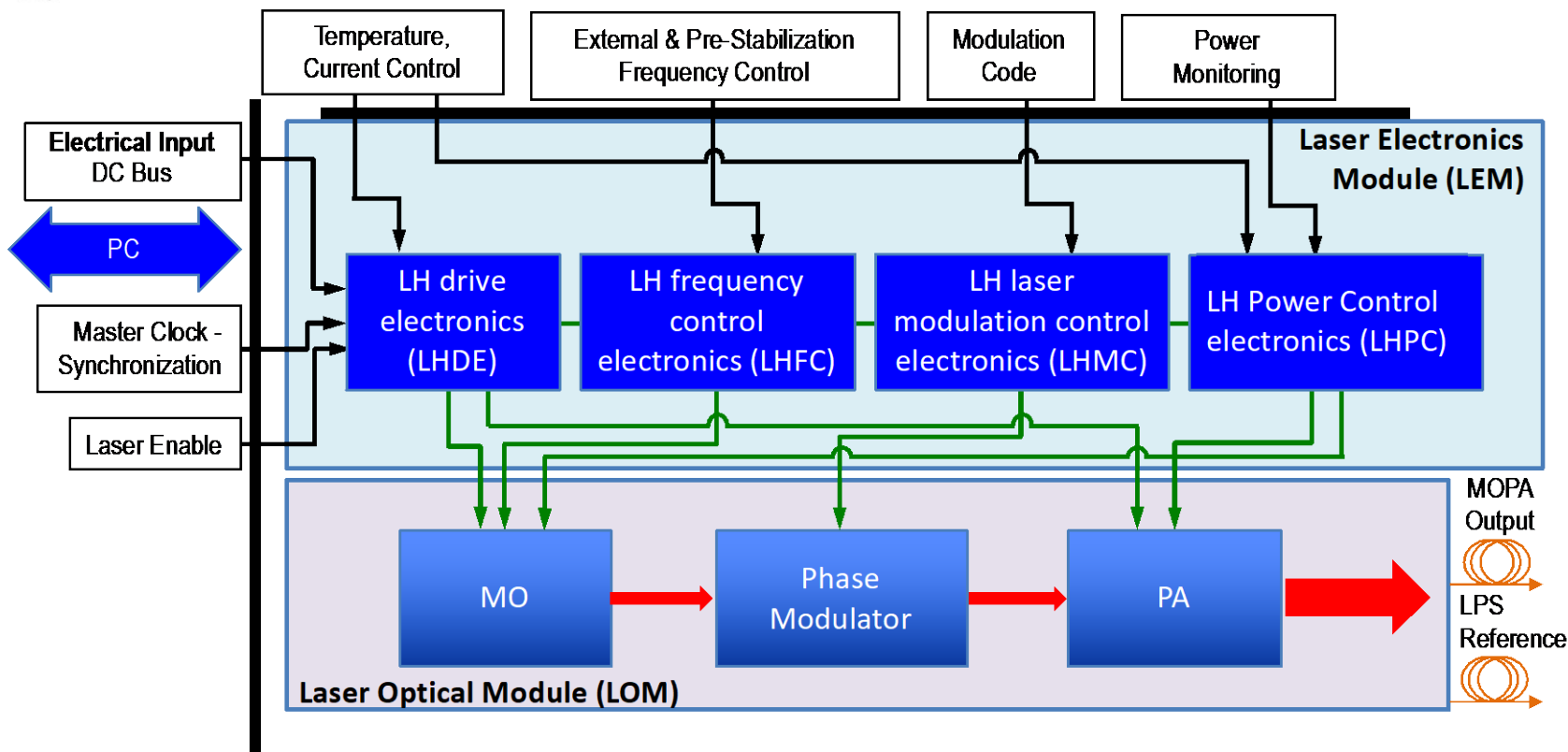

— Electrical    — Electrical/Command-Control    — Optical Fiber    — Free Space Optical

# NASA LASER ACTIVITIES FOR LISA

# MASTER OSCILLATOR

# GSFC's micro-Non-Planar Ring Oscillator ( $\mu$ -NPRO) features to address

- ❑ Larger free-spectral-range (FSR)
  - Wider mode-hop-free tuning range (more robust)
  - Less coupling from neighboring mode
- ❑ Larger overlap between pump and signal
  - Minimized un-pumped region (smaller loss)
- ❑ Smaller mass & small piezoelectric actuator
  - Wider frequency-tuning bandwidth (better in-loop noise suppression)
  - More efficient tuning (larger tuning per voltage)
- ❑ Smaller thermal volume
  - Easier thermal control, uniform temperature, faster heat extraction
  - Less electrical power for house keeping
- ❑ Smaller package possible
  - Use of telecom packaging technology
  - Alignment tolerant crystal design



Goals are to reduce size, weight and power with improved performance compared to NPRO.

# $\mu$ NPRO Performance

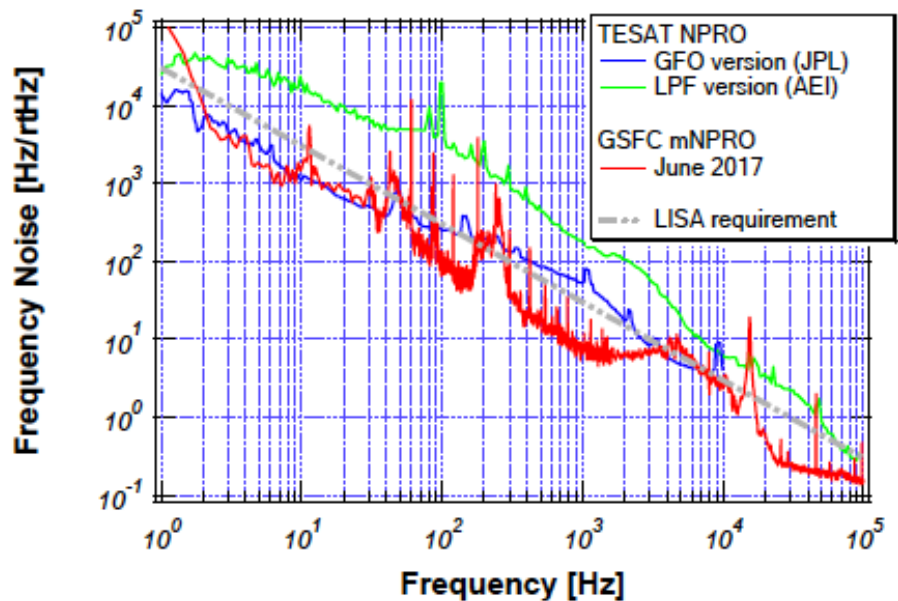
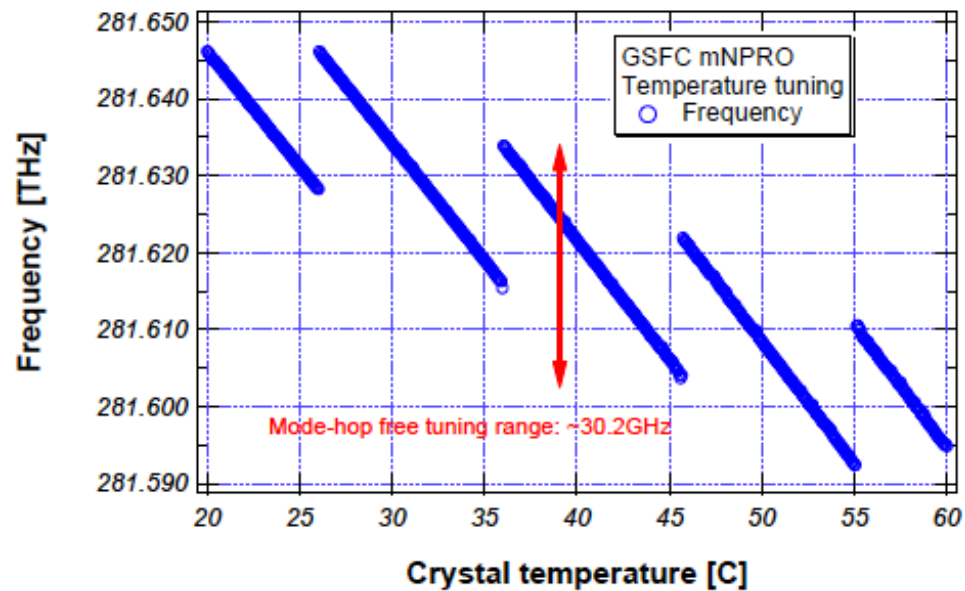

*mode-hop free tuning of >30GHz and preliminary frequency noise measurement of the  $\mu$ -NPRO laser breadboard*

# Overview of $\mu$ -NPRO Packaging Effort

- ❑ TRL5 Build and performance assessment completed. Moving to TRL6 development.
- ❑ A mechanical model has been developed in accordance with optical design and required optical alignment tolerances.
- ❑ The design allows for minimal mechanical changes to move from prototype versions where epoxy is predominantly used to hold/align optics to production where epoxy is minimized in favor of welded or soldered components.
- ❑ The design has been developed to be modular in nature such that key subassemblies may be assembled, characterized, and qualified outside the overall system.
- ❑ An overview of key subassemblies and components are shown below:

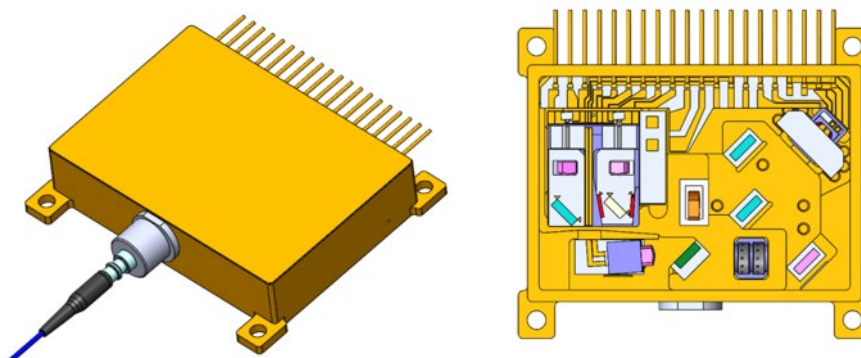

*61.2mm x 53.7mm x 14mm*

# Specifications for Packaged $\mu$ -NPRO MO

Parameter	Unit	Min	Typ	Max
<b>Output Laser</b>				
Wavelength	nm		1064	
Mode			TEM00	
Power	mW	150		
Fiber Type			PM980	
Output PER	dB		15	
Polarization Orientation			Fiber Slow Axis	
Fiber Coupling	%	50		
Fiber Facet Angle	°		8	
Fiber Connector			FC/APC	
Fiber Jacket Material			Hytrel	
Fiber Length	m		TBD	
Monitor Photodiode			Required	

<b>Package</b>				
Size	mm	<(70x45x35)		
Hermetic		Yes		
Shielding		TBD		
Mounting		TBD		

<b>Environmental</b>				
Base Temperature	°C	TBD		
Shock		TBD		
Vibration		TBD		

Parameter	Unit	Min	Typ	Max
<b>NPRO Subassembly</b>				
Material		Nd:YAG		
Entry Facet Coating		AR @808 / HR 95-99% @1064		
PZT Thickness	mm		0.5	
PZT Square Dimension	mm		4	
PZT Voltage				100
Magnet Direction		H-vector along crystal length		
Temperature Control	°C		0.1	
NPRO ROC	mm		100	
NPRO Dimensions	mm	4.499x3.0x1.2		

<b>Pump Laser</b>				
Wavelength	nm		808	
Mode		TEM00, SLM Preferred		
Power	mW	500		
Temperature Control	°C		1	
Monitor Photodiode		Preferred		

<b>Optical Assembly</b>				
Optical Material		Fused Silica, Sapphire, Rad Hard SF6		
Isolation	dB		30	
Isolator Loss	dB			2
Isolator Power	mW	300		

# Master Oscillator (MO) Status

- Working with AVO Photonics
  - TRL 4/5 MO performing well.
  - AVO is finalizing TRL 6 MO design with the goal of providing prototype for environmental tests by end of 2020.



Build process at AVO

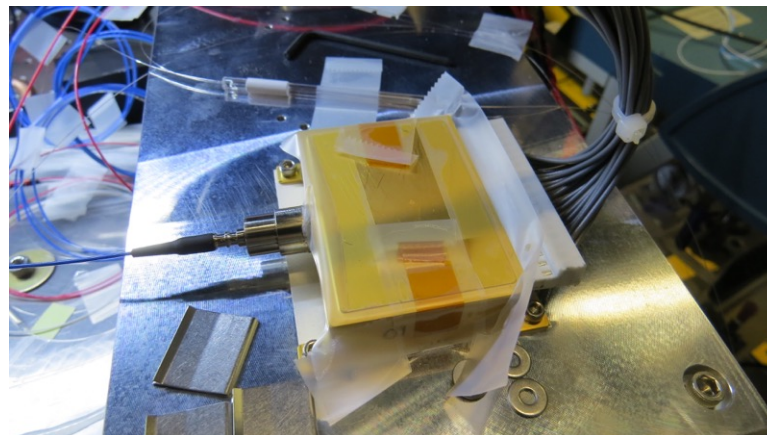

AVO ETU #1  $\mu$ NPRO package under testing

# Master Oscillator (MO) TRL 4/5 unit Performance

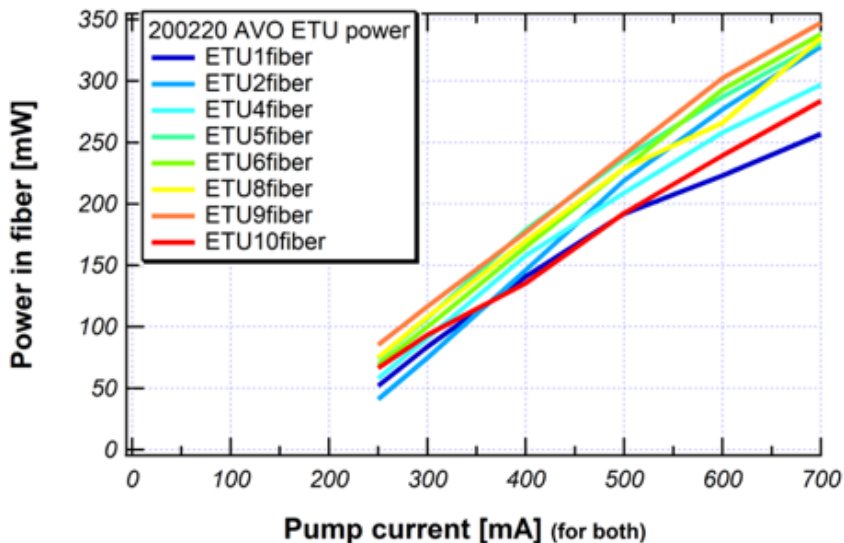

Power in fiber (ETU MOs)

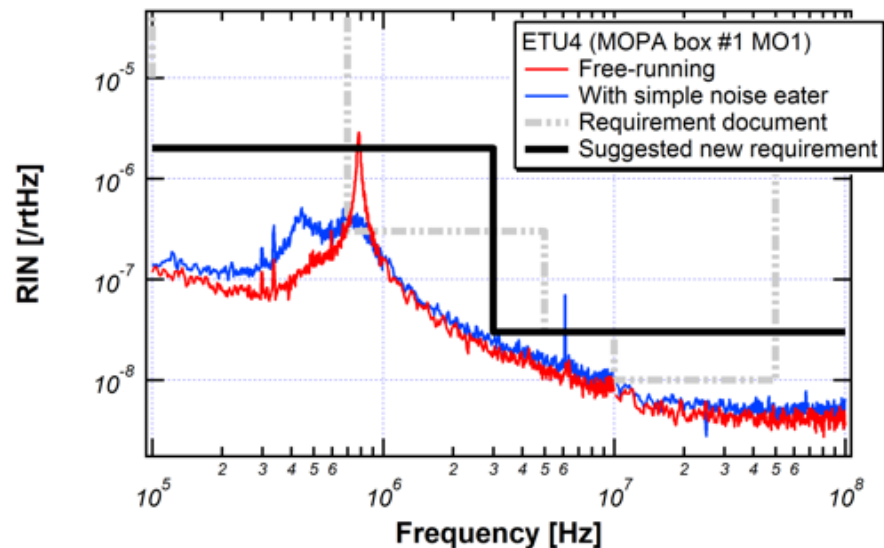

High frequency RIN (ETU MO in MOPA box)

# POWER AMPLIFIER

# GSFC Power Amplifier Breadboard Activities

- All-fiber configuration
  - >2W, continuous-wave output

Double-clad large mode area (LMA) polarization maintaining gain fiber

Forward pumping for safety & lower SBS noise

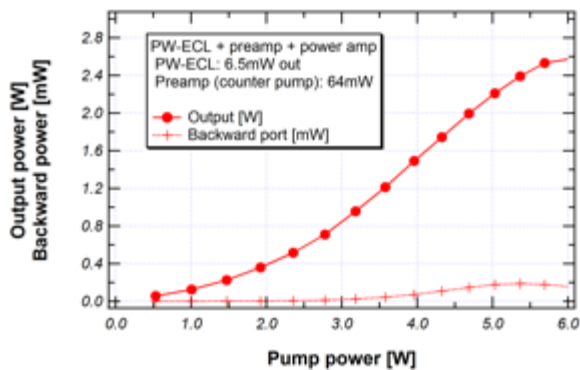
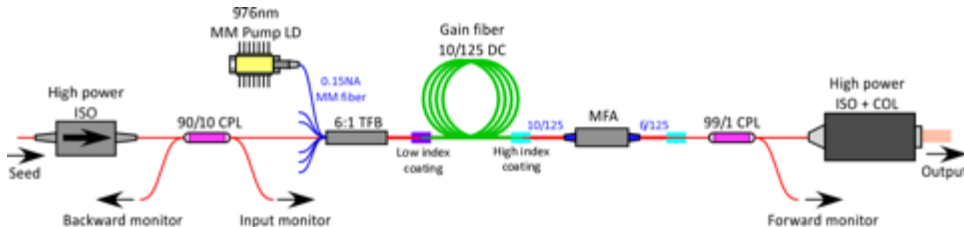

**GSFC PA performance**

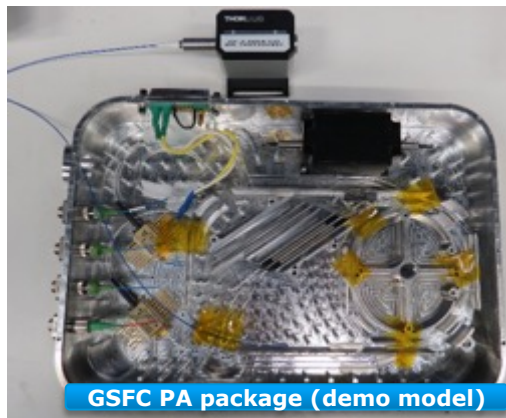

**GSFC PA package (demo model)**

# GSFC Fiber Amplifier Brassboard

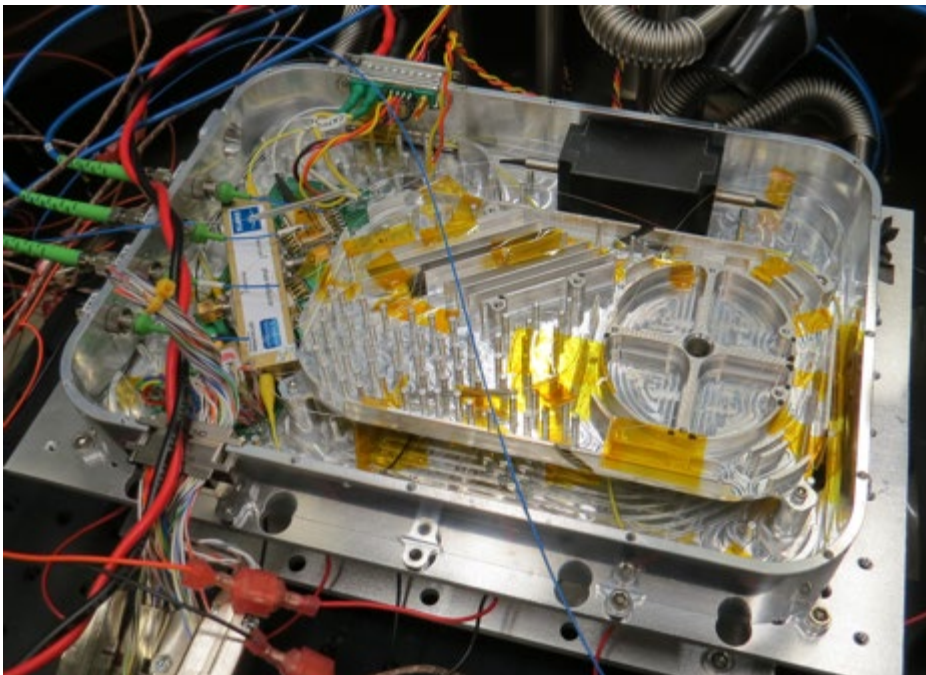

- Test amplifier built by GSFC in TVAC chamber.
- Used for environmental testing and intensity stabilization demonstration.
- Current Dimensions- 260 mm (L) x 190 mm (W) x 40 mm (H)
- This package includes both semiconductor seed laser and a fiber amplifier pumped with a single pump diode.
- We began effort to repackage this fiber amplifier to fit within the LH volume.

# TRL4/5 Power Amplifier (PA) Overview

## ❑ Built at Fibertek

- Design based on GSFC study
- Prototype PA build by Fibertek, tested at GSFC
- 2 ETUs built by Fibertek: Ruggedized version, integrated pump (3X), thermistor, etc.
- Fibertek is currently preparing for TRL 6 design review

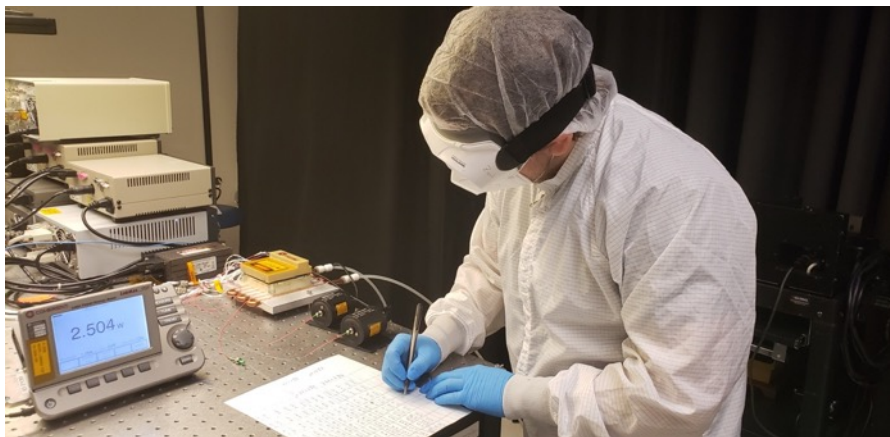

Breadboard setup to test splice

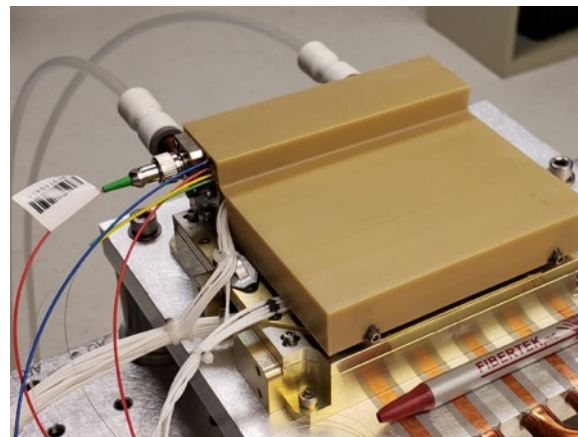

Fibertek PA ETU

# MOPA LASER

# TRL5 MOPA Mechanical Dimensions

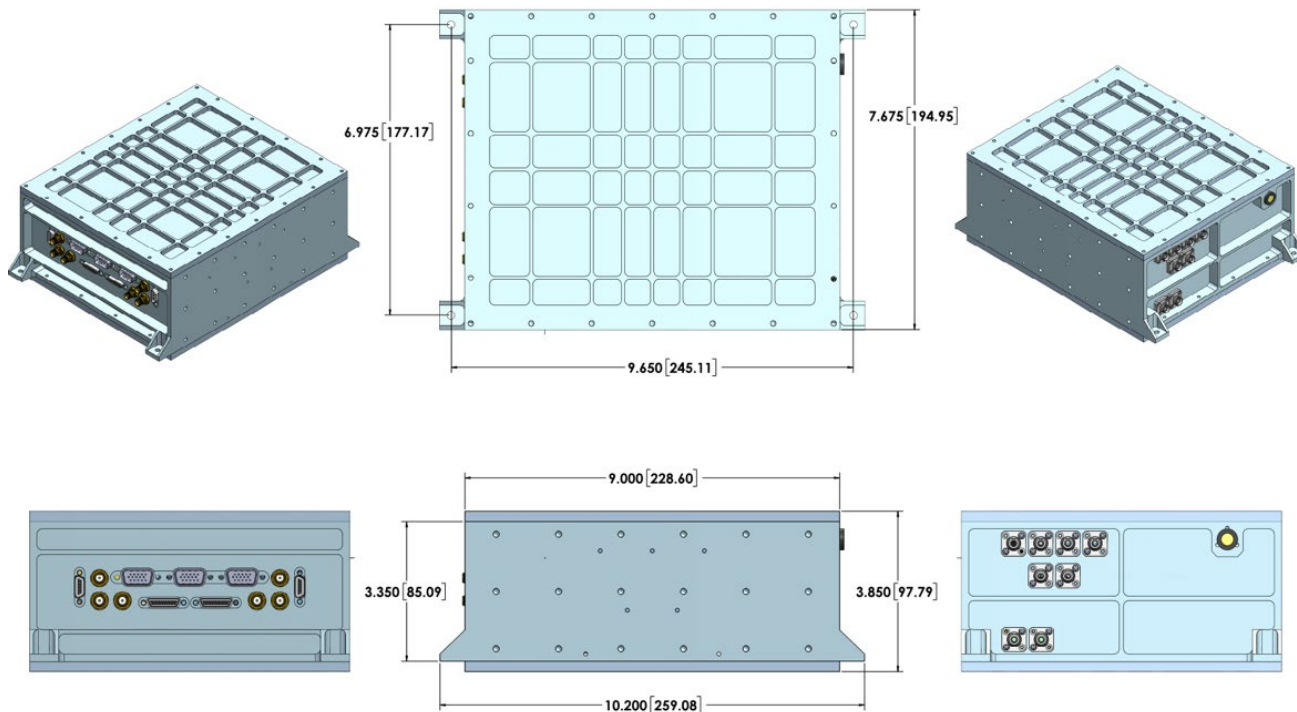

LH Allocation (Laser Requirements ver. 3.4) = 250 x 250 x 200 mm; or Volume = 0.0125 m<sup>3</sup>

Current Dimensions -

- LOM: 7.7 in (194.9 mm) x 9.0 in (228.6 mm) x 3.9 in (97.8 mm) = 266.1 in<sup>3</sup> or 0.0044 m<sup>3</sup> (~35% of Volume)
- LEM: ~65% of the remaining LH volume, or 0.0081 m<sup>3</sup>

# MOPA #1 STATUS

- ❑ MOPA box #1 mostly completed, lids closed
  - ~17 monitor thermistors.
  - Some components need to be replaced or added for completion
    - E.g. Fiber feedthrough, high-power isolator, etc.
  - Testing process delayed by COVID-19

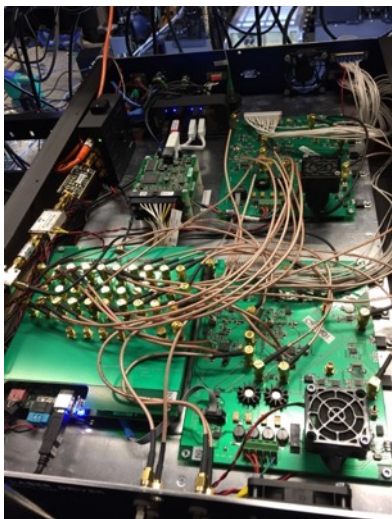

Custom (OEM) electronics for MOPA box

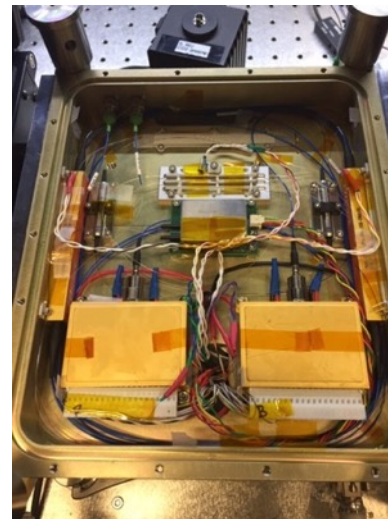
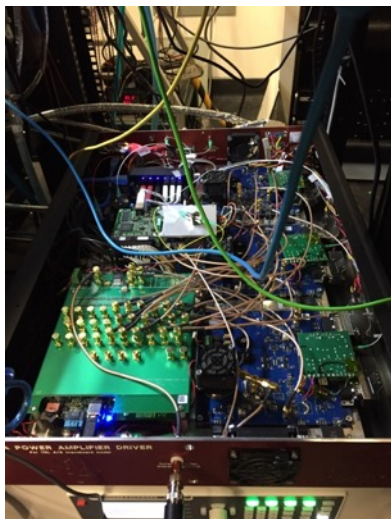

MO side of MOPA box #1

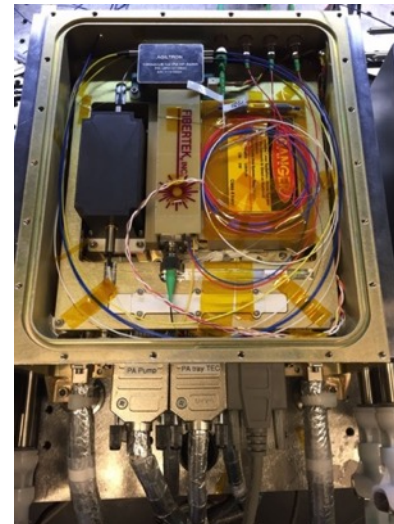

PA side of MOPA box #1

# MOPA box #1 / component performance (1/2)

## Frequency noise of ETU MOs in MOPA box #1

- Free-run
  - Meets LISA requirement. World-best level.
- Stabilized
  - Not at the (new) LISA requirement level yet.
  - Limited by the cavity locking setup.
  - To be improved with new COTS cavity setup (est. Jul. 2020 delivery)

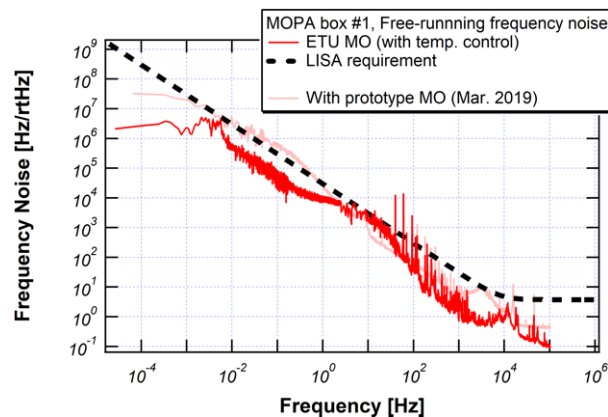

Free-running frequency noise (ETU MOs)

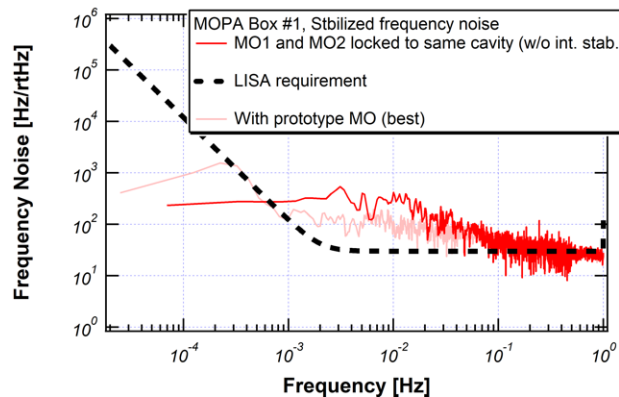

Stabilized frequency noise (ETU MOs)

# MOPA box #1 / component performance (2/2)

- Intensity noise of PA output
  - Stabilized: Reaching LISA requirement at world-best level.
- RF (differential) phase noise of PA
  - Previous Fibertek PA build at LISA requirement level.
  - Will complete assessing MOPA box #1 and 2 performance.

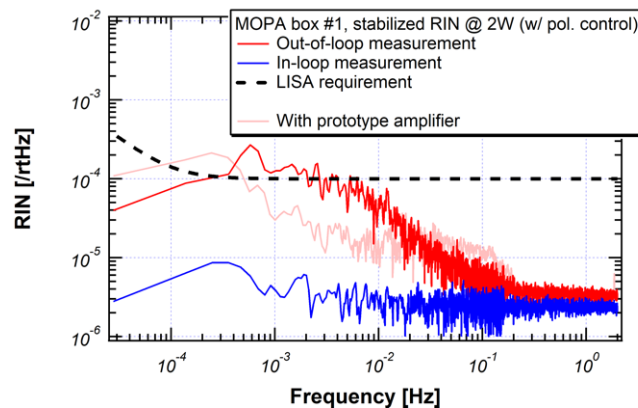

Stabilized low-frequency RIN (MOPA box #1)

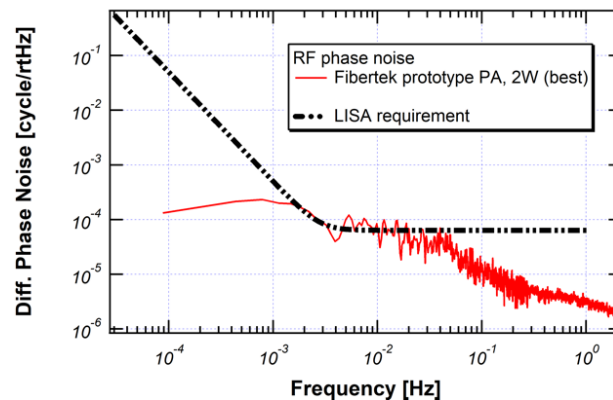

RF (differential) phase noise (Fibertek Phase 1 PA)

# LASER AND COMPONENT TEST

# COTS Breadboard Controller Rack

- ❑ (4) Arroyo 4302 laser diode drivers ( $\mu$ NPRO)
- ❑ (3) Arroyo 4304 laser diode drivers (Pump Diodes)
- ❑ (3) SLICE-QTC Temperature Controllers (4 Channels Each)
  - MO1/2 Baseplate, Crystal, Case TEC Control (6 Channels)
  - PA Fiber Tray TEC Control (1 Channel)
- ❑ Thermotek RC15A250 Chiller
- ❑ NI USB-6343 Data Acquisition Module
  - Monitor Photodiode Analog Inputs
  - Optical Switch control via DIO ports.
- ❑ Intel NUC Controller PC
  - COTS controller application developed with LabVIEW 2018.
- ❑ Rack Mount KVM
- ❑ Power Transformer and UPS



# In-House Control Electronics Rack

- MO driver box
  - 2x MO driver boards
    - 2 LD drivers / board
    - 2 temperature controller / board
  - ADC
  - Noise eater, detector
- PA driver box
  - 3x PA driver boards
    - 1 LD driver / board
    - 1 temperature controller / board
- PZT amplifier
  - 2x HV amplifier
- Intel NUC Controller PC
- Rack Mount KVM
- Power Transformer and UPS

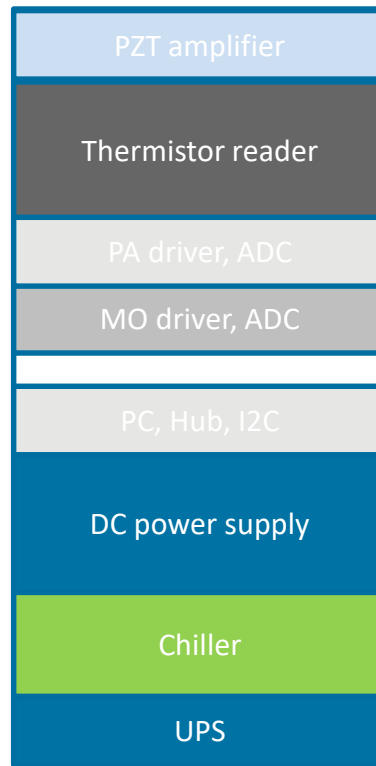

In-house driver on 22U rack

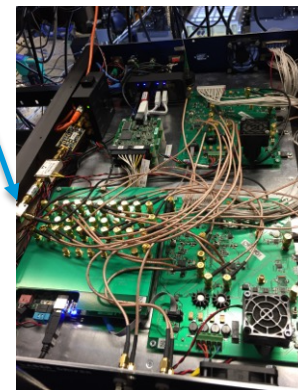
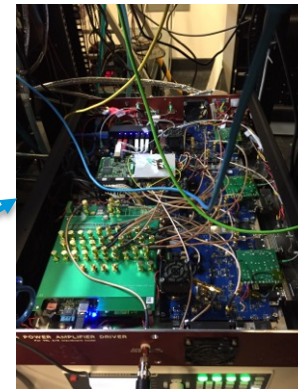

# LISA Brassboard Laser Functional Test Rack

- ❑ NI PXIe-8880 Data System (May be replaced by Dell Precision Work Station)
  - Performance Test Applications (LabVIEW 2018)
- ❑ Tektronix TDS-2024 Oscilloscope (Amplitude Modulation)
- ❑ Pendulum CNT-91 Frequency Counter (Frequency Noise, Tuning)
- ❑ RIGOL RSA 5065 Spectrum Analyzer (RIN)
- ❑ SRS SR785 Dynamic Signal Analyzer (RIN)\*
- ❑ MOKU:Lab (RIN, Frequency Noise)
- ❑ Yokogawa AQ6370 Optical Spectrum Analyzer\*
- ❑ High Finesse WS-7/Bristol 871 Wavemeter
- ❑ Thorlabs PM100 Optical Power Meters



# LASER MATURATION, RISK MITIGATION AND RELIABILITY TEST PLANS

# Laser Maturation and Risk Mitigation Plan

Laser Technology Maturation Stages	Definitions	Benefits and Risks Mitigation	Risks not Addressed in Each Stage
<p><b>Breadboard</b> <b>TRL 4</b></p> <p><b>Internal GSFC Demonstration by 12/2018</b></p>	<ul style="list-style-type: none"> <li>A low fidelity unit that demonstrates function only, without respect to form or fit in the case of hardware, or platform in the case of software.</li> <li>Most often uses commercial and/or ad hoc components and is not intended to provide definitive information regarding operational performance.</li> </ul>	<ul style="list-style-type: none"> <li>Demonstrate functionalities of the laser transmitter for LISA.</li> <li>Allow flexibility to try different layouts and investigate effects such as misalignment tolerance, temperature operation range, optical feedback, etc.</li> </ul>	<ul style="list-style-type: none"> <li>Not addressing form factor</li> <li>Not properly address thermal mgmt</li> <li>Not addressing possible stray lights, potential optical feedbacks from closely packed components</li> <li>Not addressing potential opto-mechanical interference</li> </ul>
<p><b>NASA – Brassboard or Engineering Test Unit (ETU) or TRL4/5</b></p> <p><b>Planned Delivery on 5/2020, delayed due to COVID-19</b></p>	<ul style="list-style-type: none"> <li>A medium fidelity functional unit that uses as much operational hardware as possible.</li> <li>Begin to address scaling issues associated with the laser system.</li> <li>Structured to be able to operate in simulated operational environments in order to assess performance of critical functions.</li> </ul>	<ul style="list-style-type: none"> <li>Demonstrate form factor and functionality.</li> <li>Allow investigation of closely packaged optical components and potential stray light and feedback issues in flight laser.</li> <li>Allow feedback on thermal design and management for the full up laser and if needed, make design change.</li> <li>Lifetest to demonstrate design ruggedness.</li> </ul>	<ul style="list-style-type: none"> <li>Not addressing environmental test concerns</li> <li>Not addressing sealed or pressurized laser performance.</li> <li>Not addressing external environment for actual space deployment, i.e. vacuum.</li> <li>Not addressing laser electronics – use COTS electronics only</li> </ul>
<p><b>NASA - TRL 6 Engineering Model</b></p> <p><b>Planned Delivery on 7/2021</b></p>	<ul style="list-style-type: none"> <li>A high fidelity unit that demonstrates critical aspects of the engineering processes involved in the development of the operational unit.</li> <li>Intended to closely resemble the flight unit to the maximum extent possible.</li> <li>Built and tested so as to establish confidence that the design will function in the expected environments.</li> <li>The ETU could become the final product, assuming proper traceability has been exercised over the components and hardware handling.</li> </ul>	<ul style="list-style-type: none"> <li>Include all lessons learned from EM build and iterate on EM design to minimize turn-around time.</li> <li>Demonstrate form factor and function in a flight like configuration and in relevant environment.</li> <li>Use proven opto-mechanical designs for packaging to minimize potential problems.</li> <li>Full demonstration of laser performance in relevant environment including laser electronics</li> <li>Lifetest of ETU to build confidence on the laser functionality and reliability for LISA</li> </ul>	<ul style="list-style-type: none"> <li>Not addressing flight laser build process and quality control.</li> </ul>

# Risk Assessment

Risks	Likelihood	Mitigation	Post-Mitigation Residual Likelihood
Reliability / lifetime	Medium to High	<ul style="list-style-type: none"> <li>Derating</li> <li>Life test</li> <li>Leverage lessons learned from previous missions</li> <li>Redundancy</li> <li>Components evaluation and selection</li> </ul>	Medium
Early failure of pump diodes	Low to Medium	<ul style="list-style-type: none"> <li>CW pump diodes with derating</li> <li>Lower peak power than previous missions</li> </ul>	Low
Laser damage	Low to Medium	<ul style="list-style-type: none"> <li>Internal fluence significantly lower than previously built lasers</li> <li>Pressurized enclosure to minimize contamination induced damage</li> <li>Follow established quality control and build processes</li> </ul>	Low
Laser system doesn't meet LISA noise requirements after environmental testing	Low	<ul style="list-style-type: none"> <li>Build engineering model using knowledge gained from laboratory studies.</li> <li>Maintain vigorous testing program throughout laser program</li> </ul>	Low
Components/Vendors Availability	Medium to High	<ul style="list-style-type: none"> <li>Qualify multiple vendors as early as possible</li> <li>Reliability tests</li> <li>Work closely with vendors to address issues and find replacement</li> </ul>	Medium

# FAILURE HAZARDS for 10 Year Life

1. Radiation-induced degradation of
  - a) Amplifier
  - b) wavelength stabilization reference FBG, VBG, other
  - c) Fiber Darkening or gain changes.
2. Seed Laser/Master Oscillator Module
  - a) Alignment Shifts and Package Induced-Failure (PIF)  
(e.g. stress-relaxation in sub-mount or solder, beam steering, cavity thermal gradients, pump beam profile changes, gain medium)
  - b) In-Situ metallurgical changes (e.g. tin whiskers)
  - c) Photochemistry (e.g. carbon deposition on pumps)
  - d) Back Facet Monitor leakage current changes
  - e) Competition for gain from scattered light
3. Amplifier
  - a) Stress-concentration in TFB
  - b) Polarization Extinction Ratio (PER) changes
4. Shock-Vibration
  - a) Shear mode failure of TEC couples
  - b) Other (e.g. fracture-dynamics)

# Goals and Structure of the Reliability Plan

An effective reliability program requires more than life-testing components and subsystems; it requires both

1. establishing screening criteria, handling procedures, installation procedures, test procedures, and operating conditions or set points, and
2. understanding the physics of failure of relatively high-risk components so that the conditional probability of failure is minimized.

*The reliability program must guide the design of the screening protocols then provide proof (or disproof) of the efficacy of the screens, procedures and choice of operating conditions.*

# RELIABILITY TEST PLAN WORK FLOW

- 1) Establish Failure Criteria
  - a) List (e.g. Power declines to <2 Watts, frequency /intensity noise, etc.)
  - b) Prioritize/Rank
- 2) Develop Draft of Bill of Materials (BOM)
- 3) Tabulate Limited Life Items from BOM  
(e.g. estimate FIT rate of components; this is dependent on Failure Criteria)
- 4) Analyze design for reliability tradeoffs  
(complexity, redundancy/sparing, de-rating, re-configuration/switching)
- 5) Perform Design Failure Modes and Effects Analysis (DFMMEA)
- 6) Prepare Reliability Test Plan
  - a) Critical Components (as determined from limited life analysis)
  - b) Subsystem
  - c) System

Steps 2-5 are iterative.

# Grouping of Components

Our plan is to group components into Groups 1, 2, and 3, defined as follows:

- **Group 1:** Those components which are either critical or for which one must both use very stringent or extraordinary screening techniques and analysis of the physics-of-failure to reduce the *a posteriori* FIT rate to less than 100.
- **Group 2:** Those components, for which we deem normal screening techniques can reduce the conditional or *a posteriori* FIT rate (i.e. the FIT rates expected after passing the screen) to less than 100.
- **Group 3:** Components, usually passive, with *a priori* FIT rates less than 100.

# Group 1 & 2 Components

Subassembly	Component or Element	Priority	BEFORE Estimated FIT Rate, peak, 90%, 16 year	AFTER Estimated FIT Rate, Advanced Screen	Estimated Activation Energy (eV)	Quantity per Assembly	Sample Size
Master Oscillator	Pump Laser Diodes, 808 nm	10	2000	200	0.35	2	30
Power Amplifier	Pump Laser Diodes, 976 nm	10	500	50	0.45	2	30
Power Amplifier	Pump combiner (TFB)	9.5	300 Group 1	30	0.48	1	30
Master Oscillator	TEC - Pump Diode	8.5	200	20	0.51	1	30
Master Oscillator	TEC - m-NPRO module	8.5	200 Group 2	20	0.51	1	30
Integrated Module	2x1 Switch, PM, 1 um, MEMS	10	143	15	0.54	2	30
Power Amplifier	Isolator-ASE filter hybrid	8	125	15	0.55	1	30

Default sample size 24



# Methodologies for Groups 1 & 2 Components

## GROUP 1 METHODOLOGY

- Group 1 components will be subjected to physics-of-failure analyses that address infant mortality, random failure, and wear-out mechanisms to support the selection of screening and burn-in criteria, life-test design, and End-of-Life (EoL) calculations, respectively.
- We will use our physics-of-failure analyses to protect against “excess acceleration” in life-test, establish the maximum acceleration that does not introduce irrelevant failure modes, and estimate the parameters of a reduced-order Accelerated Stress-Deposition Model (ASDM).

## GROUP 2 METHODOLOGY

Group 2 components and modules, e.g. the 2x1 switch, isolator-collimator, and m-NPRO TEC will be life-tested with ASDM. The m-NPRO TEC will also be subjected to the following tests.

AC Resistance Test [before and after each environmental stress (TVAC and radiation) test A, B, C]
Insulation Resistance Test [before and after each environmental stress (TVAC and radiation) test]
Temperature Cycling Series
Thermal Performance Test (including heat load testing) : High, Low
Vibration : Sine, Random
Mechanical Shock
Life Test Ambient Temperature: 60C Current: Maximum Operating current Cycle Time: 1 minute ON, 1 minute OFF (exact time depending on the thermal time constant of the assembly) Number of cycles: 1000

# Group 3 Components

Subassembly	Component or Element	Priority	BEFORE Estimated FIT Rate, peak, 90%, 16 year	AFTER Estimated FIT Rate, Advanced Screen	Estimated Activation Energy (eV)	Quantity per Assembly	Sample Size
Integrated Module	Phase Modulator	10	80	15	0.59	1	18
Master Oscillator	Optical Isolator	8	75	10	0.59	1	18
Power Amplifier	Optical Isolator	8	75	10	0.59	1	18
Master Oscillator	PZT element	8.5	60	6	0.61	1	18
Power Amplifier	Cladding power stripper	8	50	5	0.63	1	11
Master Oscillator	Nd:YAG	5	50	5	0.63	1	11
Master Oscillator	Polarization Combiner	2	40	4	0.66	1	11
Power Amplifier	Mode-field adapter	8	20	20	0.73	1	11
Master Oscillator	Collimator	2	20	10	0.73	1	11
Power Amplifier	Gain fiber	6	16	16	0.76	1	11
Integrated Module	Harness	1	15	10	0.76	1	11
Power Amplifier	In-line monitor	8	12	6	0.79	2	11
Master Oscillator	Monitor Photodiode	7	12	12	0.79	2	11
Master Oscillator	Back Facet Monitor Diode	7	12	12	0.79	2	11
Power Amplifier	Monitor diode	7	12	12	0.79	2	11
Integrated Module	Monitor Photodiode	7	12	12	0.79	2	11
Master Oscillator	Mode Matching Optic	2	10	5	0.81	1	11
Integrated Module	Tap Monitors	7	6	6	0.88	1	11
Power Amplifier	Low index coating	5	5	5	0.91	1	11
Master Oscillator	Submounts	2	5	5	0.91	1	11
Master Oscillator	Mirror	2	5	5	0.91	1	11
Master Oscillator	Half Wave Plate	2	5	5	0.91	1	11
Master Oscillator	Mirror	2	5	5	0.91	1	11
Master Oscillator	Lenses	2	5	5	0.91	2	11
Master Oscillator	Mirror	2	5	5	0.91	3	11
Master Oscillator	Mounts	1	5	5	0.91	8	11
Master Oscillator	Housing	1	5	5	0.91	1	11
Integrated Module	MOPA Housing	1	5	5	0.91	1	11
Master Oscillator	Magnet	3	4	4	0.94	1	11
Master Oscillator	Preforms	1	3	3	0.98	10	11
Integrated Module	Mechanical Parts	1	3	3	0.98	25	11
Power Amplifier	Fused Fiber coupler	2	2	2	1.05	3	11
Master Oscillator	Fast Axis Collimator	2	2	2	1.05	2	11
Master Oscillator	Slow Axis Collimator	2	2	2	1.05	2	11

## GROUP 3 METHODOLOGY

- The test plan for Group 3 components includes 100% functional testing.
- The plan also calls for Process Failure Modes and Effects Analysis (PFMEA) to ensure that our handling, testing, and installation processes do not introduce latent defects or damage.

# AVAILABLE RESOURCES AND FACILITIES FOR LASER ASSEMBLY AND COMPONENT TESTING

# Pump Laser Diode Array (LDA) Testing

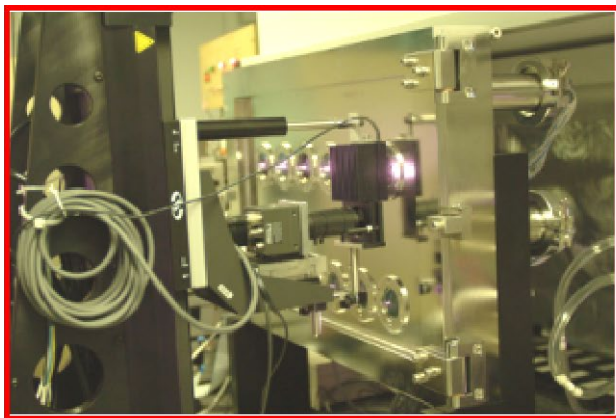

Fully automated custom vacuum chamber with 12 LDA test positions & windows for continuous inspection

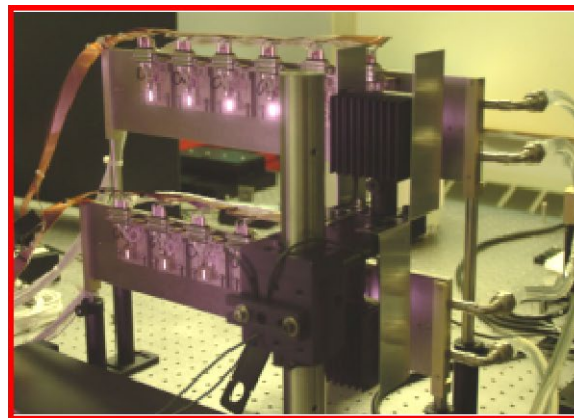

Fully automated custom test station with 12 LDA test positions & continuous power measurement capability



2<sup>nd</sup> test station with 12 LDA test positions & continuous power measurement capability

# NASA GSFC Space Laser Assembly Cleanroom (SLAC)

SLAC consists of three designate rooms for space flight lasers build

- ❑ Room #1
  - Bonded storage of flight hardware.
  - Wet and dry cleaning stations for flight hardware
- ❑ Room #2
  - 3 optical tables for the flight build as well as storage of any hardware & tools needed during the building process.
- ❑ Room #3
  - TVAC Chamber for TVAC Cycling.
  - Optical table for testing during TVAC Cycling.

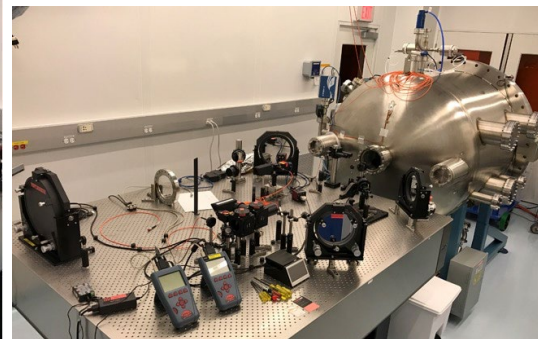
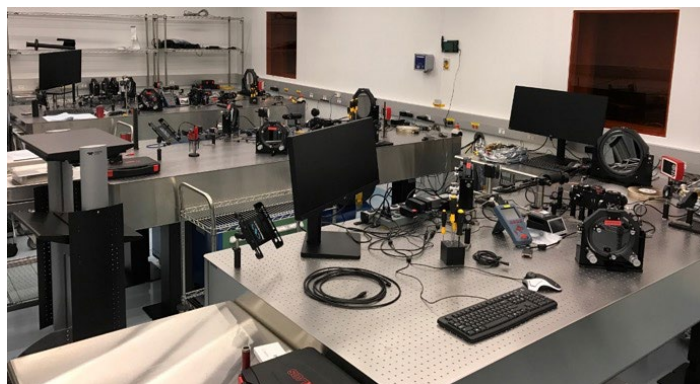
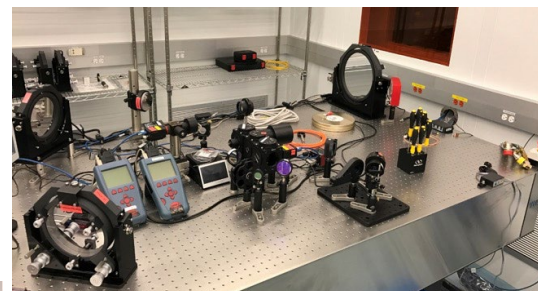

# How do We Assess the LISA Laser Performance?

GSFC's unique laser characterization infrastructure for laser evaluation

- Unique testing capabilities
  - Frequency noise measurement & stabilization
  - Intensity noise measurement and stabilization
  - Differential phase noise measurement
  - Other laser/amplifier evaluation capabilities
  - These *in-situ* test capabilities will provide immediate feedback to minimize build/test time cycle
- Conducting an *in-situ* test activity provides important advantages and benefits including: time savings, cost savings, and improved ability to meet compliance requirements
- A common problem that occurs in the integration and testing of a MOPA laser are unanticipated work/issues. Performing an *in-situ* test avoids costly redesign and troubleshooting
- This unique infrastructure **does not exist** in industry, Government labs or academia

# Frequency Noise Measurement & Stabilization

- **Dual Band Frequency noise measurements**
  - Low frequency (0.1mHz~100Hz)
    - Optical beat note against iodine-stabilized laser\*
    - High frequency (100Hz~1MHz)
    - Anti-symmetric fiber Mach-Zehnder interferometer in vacuum
- **Frequency noise stabilization**
  - Test to see if the laser can be stabilized to LISA requirement
    - Iodine frequency reference\*
    - Optical cavity\*



Fiber Mach-Zehnder



Iodine-stabilized laser system



Optical cavity

# Intensity Noise Measurement & Stabilization

- **Dual Band Intensity noise measurements**
  - Low frequency (0.1mHz~1Hz)
    - Temperature-stabilized, large area photodetector
  - High frequency (1Hz~50MHz)
    - High-power, fast photodetector
- **Intensity noise stabilization**
  - Test to see if the laser can be stabilized to LISA requirement
    - Temperature-stabilized, large area photodetectors in vacuum\*

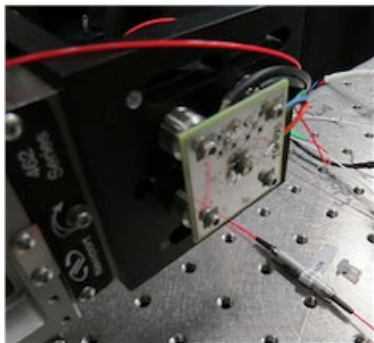

High power, fast photodetector

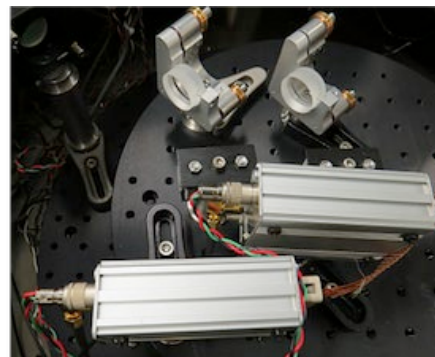

Temperature-stabilized, large area photodetector in vacuum

# Differential Phase Noise Measurement

## Concept

- Phase lock 2 lasers, transmit through fiber amp, and measure the phase difference
  - o Requirement set by clock noise transfer between S/Cs
- **Very difficult measurement\***
  - Need to suppress any other effects, including:
    - o Temperature drift(s) of components (e.g. gain fiber)
    - o Intensity-to-phase coupling , RF signal leakage, feedthrough, and the like.

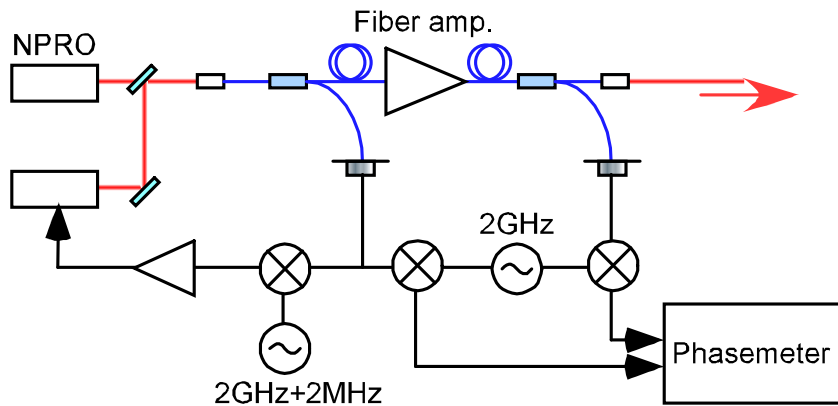

Setup concept of amplifier's differential phase noise measurement

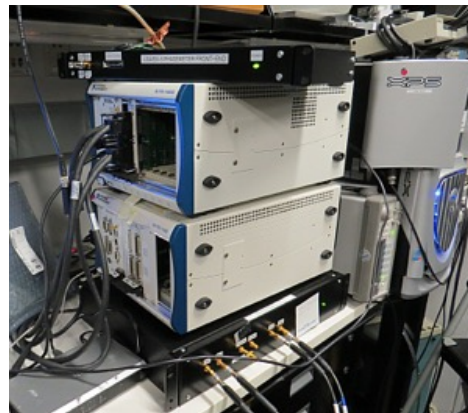

LISA Phasemeter (provided by JPL)

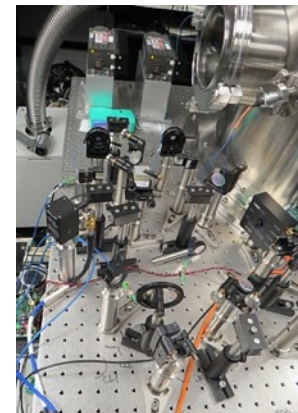

Two phase locked lasers

# Other Laser/Amplifier Evaluation Capabilities

- **Optical analysis**
  - Optical spectrum analyzer, scanning Fabry-Perot
  - Power, polarization, etc.
  - Tuning range, speed, phase-locking performance analysis\*, etc.
- **Environmental tests**
  - TVAC test, vibration test, Gamma radiation test, etc.
- **Life tests**
  - Long term monitor, clean room facility, etc.

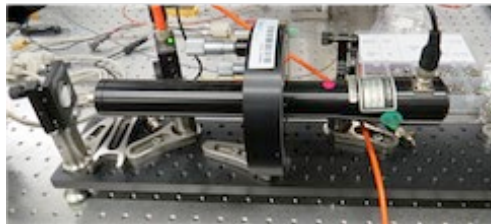

High-resolution scanning FP

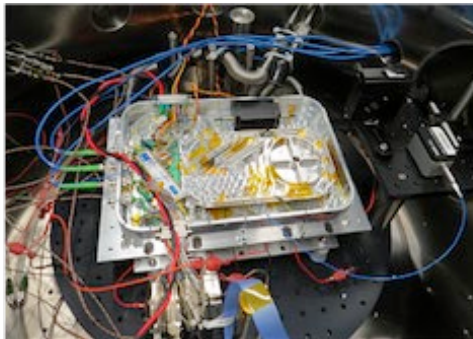

Laser system in TVAC chamber

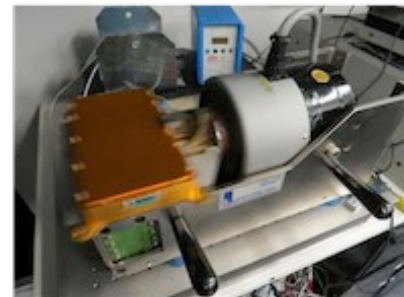

Preamp under vibration

# Notional Schedule for Laser Development

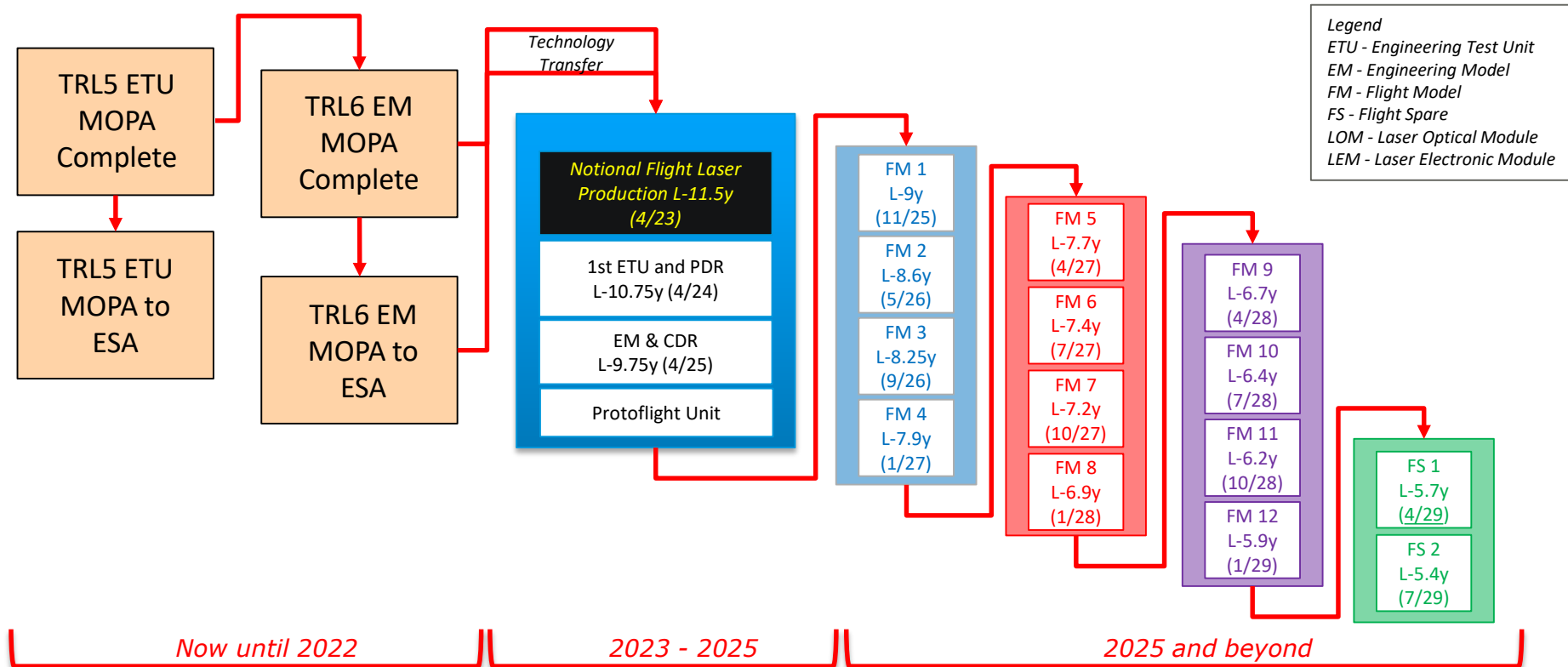

# Organizational Chart

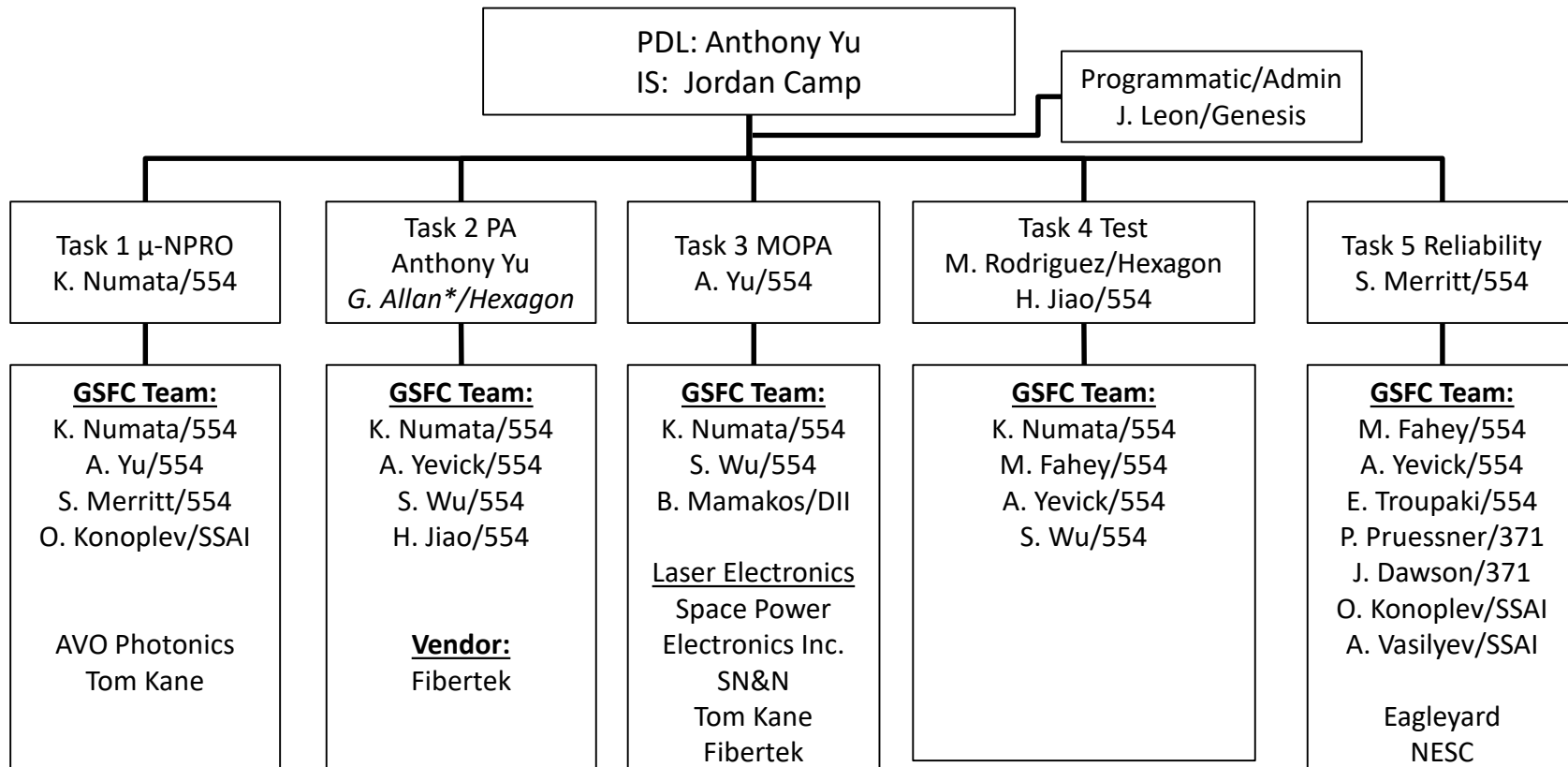

\* Our friend and teammate Graham Allan passed away May 14, 2020. We are grateful for his many contributions to this project. No decision has been made regarding his replacement.

# Summary

## ❑ LISA laser development opportunity

- Ultra-stable laser to enable picometer interferometry in space
  - Mission led by ESA/Europe, ~2034 launch.
- Laser: one of a few potential technology contributions from the U.S.
  - TRL 6 level laser system by mid 2021

## ❑ MOPA configuration

- Low power, low noise master oscillator
  - ~150mW CW, precision frequency/phase lockable laser
  - Only NPRO satisfies LISA requirement
  - TRL6  $\mu$ NPRO prototypes by end of 2020
- Low noise power amplifier
  - ~2W CW, low noise amplifier (low RIN, low differential phase noise)
  - Baseline design: Yb LMA gain fiber
  - TRL6 PA module by end of 2020